

**MINISTRY OF DIGITAL ECONOMY AND
ENTREPRENEURSHIP
(MODEE)**

NATIONAL BROADBAND NETWORK

**REQUEST FOR PROPOSAL FOR
REPAIRING CIVIL WORKS & FIBER CABLES
AND ROUTES TRANSFERRING
FOR
NORTH REGION'S FIBER OPTIC NETWORK
(IRBID, NORTH GHOUR, JARASH, AJLOUN, AND
MAFRAQ)**

**MINISTRY OF DIGITAL ECONOMY AND ENTREPRENEURSHIP
P.O.BOX 9903 AMMAN 11191 JORDAN**

Tender Deadline / / 2021

TABLE OF CONTENTS

1. PROJECT OVERVIEW	4
1.1. INTRODUCTION	4
1.2. SCOPE OF WORK	5
2. WORKS REQUIREMENTS	15
2.1. GENERAL	15
2.2. WORKS SERVICES	15
2.3. SERVICE LEVEL REQUIREMENTS (SLR)	15
2.4. REQUIREMENTS AND INSTRUCTIONS	15
2.5. OBTAINING REQUIRED PERMISSIONS	17
2.6. FIBER WORKS PRINCIPLES	18
2.7. CIVIL WORKS PRINCIPLES	22
2.8. ADSS CABLES TRANSFEERING	27
2.9. WARRANTY	27
3. Annexes	28
Annex A: Duct and Joints Specifications	28
Annex B: Chambers Specifications	30
Annex C: Trench Specifications	34
Annex D: Route Crossing	38
Annex E-1: Warning Tape	39
Annex E-2: Electronic Identifiers	40

Annex F-1: Technical Specifications of Optical Fiber Cable - Duct Type	42
Annex F-2: Technical Specifications of Optical Fiber Cable - Aerial Type	51
Annex F-3: Technical Specifications of Optical Distribution Frame	61
Annex F-4: Technical Specifications of Mini Optical Distribution Frame	65
Annex F-5: Technical Specifications of Optical Connectors and Adapters	68
Annex F-6: Technical Specifications of Optical Cable Splice Enclosures	71
Annex F-7: Technical Specifications Duct Cable Hardware & Support Accessories	76
Annex F-8: Technical Specifications Aerial Cable Hardware & Support Accessories	78
Annex G: Aerial Cable sag and clearance	84
Annex H: Test and Acceptance Specifications	85
Annex I: Shop Drawing / As-Built Specifications	93
Annex J: Service level Agreement (SLA)	98
Annex K: List of existing North Region (Irbid, North Ghour, Jarash, Ajloun, and Mafraq)	
Site Names	102
Annex L: Safety Requirements of IDECO	122
Annex M: Safety Requirements of EDCO	126

1. PROJECT OVERVIEW

1.1. INTRODUCTION

MODEE through its National Broadband Network Program (NBN) has implemented parts of the NBN Network in Amman, Aqaba Region, North Region (Irbid, Ramtha, North Ghour, Jarash, Ajloun, and Mafrq), and South Region (AL- Karak, South Ghour, AL-Tafilah, and Ma'an) connecting government entities, schools, Knowledge Station, medical centers, hospitals, with a Ring in each governorate -that includes Aggregate Points- to the NBN, Ultimately these regions (Modules) will be interconnected by an overlay network- to complete the "National Broadband Network"- through the existing National Electrical Power Co (NEPCO)'s Substations.

North Area (Irbid, North Ghour, Jarash, Ajloun, and Mafrq) was implemented by constructing new civil works and by using Irbid District Electricity Company (IDECO) low and medium voltages poles for hanging All Dielectric Self Supported (ADSS) aerial cables.

The existing Network in the North region Contains and expands to cover Three geographical locations (Irbid, North Ghour, Jarash, Ajloun, and Mafrq) and consists of **461** entities Distributed as follows:

- **385** Schools, Directorate of Education, and Knowledge Station.
- **20** medical centers.
- **2** sites for NEPCO (National Electric Power Co).
- **54** Government Entities.

The Entities mentioned above are connected with Duct and /or Aerial fiber optics cable network with the following lengths.

- **360** Km ADSS (All Dielectric Self Supported) cables hanged on IDECO electrical poles (Low and Medium Voltage poles).
- **712** Km of In-Duct fibers installed in routes belonging to MODEE.

1.1.1. O&M - OPERATIONS AND MAINTENANCE UNIT OF MODEE

The Operations and Maintenance Unit (O&M) at MODEE is responsible for the entire program Operations and Maintenance of the Network through its Representative who will be involved to manage and supervise the contractor's works.

1.2. SCOPE OF WORK

The scope of work of this tender is the existing Network in the North Area (Irbid, North Ghour, Jarash, Ajloun, and Mafraq) and consists of the following:

1.2.1. In order to keep the Network available 100 % all the time, the contractor shall provide a proposal that comply with the below sections for repairing the expected fiber routes & fiber cable :

➤ **Fiber Route Repair:**

Repairing the expected Fiber route (Duct type Civil Works) damages that may occur on the existing routes or Transferring sections of existing routes, The proposal shall comply with the attached Service Level Agreement (SLA) as stated in Annex J to repair the fiber routes damages by repairing, supplying and installing all needed materials including manholes, handholes, pull-boxes and accessories (example : U-Guard, PVC pipes inside entities,.. etc.).

➤ **Fiber cable Repair:**

Repairing the expected Fiber cable cuts that may occur on the existing route. The proposal shall comply with the attached Service Level Agreement (SLA) as stated in Annex J to repair the fiber cable cuts by repairing, supplying and installing all needed materials (cables, cable mounting accessories, ODF, splicing enclosures, boxes, and optical patch panels,..etc.). In addition to the splicing of the cables, the end-to-end testing of installed optical network sections.

➤ **Connecting new entities:-**

Bidders shall provide proposals for connecting new entities that may be needed. The proposal shall comply with the attached Service Level Agreement (SLA) as stated in Annex J to connect new entities by supplying and installing all needed materials Civil works including route excavation and reinstate, manholes, handholes, pull-boxes and accessories (example : U-Guard, PVC pipes inside entities,.. etc.).And Fiber works including Duct/ADSS cables, cable mounting accessories, ODF, splicing enclosures, boxes, and optical patch panels,..etc.). In addition to the splicing of the cables, and the end-to-end testing of installed optical fibre sections,

➤ **ADSS Routes Transferring:-**

Bidders shall provide proposals for any required transferring of the ADSS cable routes that may be needed on the existing network. The contractor shall comply in his proposal with the attached Service Level Agreement (SLA) stated in Annex J for the time needed for any transferring work on the routes.

➤ **Removing cables:-**

Bidders shall provide proposals for any required disassemble of ADSS/Duct type fiber optic cable for all sizes and accessories off the electrical poles /Routes, and store cable and accessories that can be reused in the contractor's store until used or transferred to MoDEE upon request.

- The cables shall be reeled on a wooden drum
 - The diameter of the drum barrel shall be large enough to prevent damage to the cable during reeling or unreeling
 - The drum shall be durable and constructed such as to prevent damage to the cables during Transportation and handlings
-
- Payment to the contractor shall be based on a re-measured actual quantities executed for fiber installed and other related items in accordance with related unit rates mentioned in the Bill of Quantities (BOQ) in Volume 5, noting that all costs incurred by the bidder for all other related items should be included in the bidder's unit rate.
 - The bidder is advised to visit and examine the Site of the Works and its surroundings and to obtain for himself on his own responsibility and expenses all information that may be necessary for preparing the tender and for performing the Works.
 - Tender Duration shall commence from the day of issuance of the order to proceed (OTP) by MODEE for the whole of the Works and shall continue for a duration of 548 days.
 - All supplied materials shall be new, unused and of high quality approved by the MODEE's Representative. Therefore the contractor shall submit not less than 2 samples of each type of the supplied materials to be approved.
 - The Contractor shall coordinate with MODEE for the handing over after finishing the work of each fiber cut or route transfer is completed.
 - Completion of the works means that the Contractor must finish all the needed works (Civil & Fiber) and tests for repairing a Fiber Cut or Route Transfer, and have everything in working order during completion times stated in the SLA of Annex J of the RFP.
 - The contractor shall be responsible for any needed coordination with all related authorized stakeholders (Ministry of Public Works and Housing MoPWH, Municipalities, Electrical companies ... etc.), he is also responsible for all needed route surveys, ROW (Right Of Way), transportation, delivery, installation and testing and all costs incurred shall be included in the Bidder's unit rates.
 - The contractor shall coordinate with the stakeholders that have an agreement with the MODEE for all the needed permits, this includes: Irbid District Electricity Company (IDECO), Electricity Distribution Company (EDCO), National Electrical Power Company (NEPCO), and all government entities connected to the network in the North Area (Irbid,

North Ghour, Jarash, Ajloun, and Mafraq). The contractor also shall comply and be aware of all the regulations and safety standards of the above mentioned stakeholders.

- The route maps of the existing Network are shown in the figures below whereas the Ring Duct Routes is drawn in Red, while Access ADSS Routes is drawn in Green, and detailed maps are attached to the RFP.

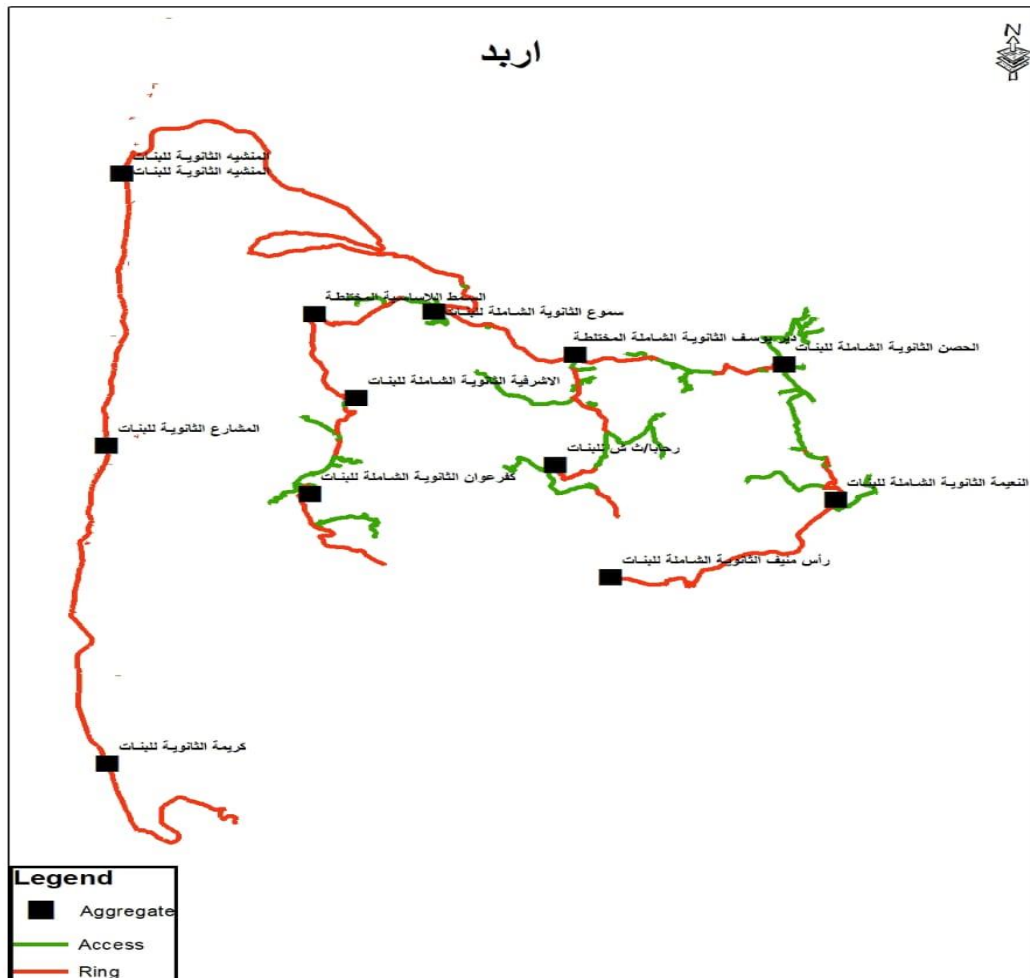

Figure 1: Module 2 Fiber Route – Irbid and North Ghour

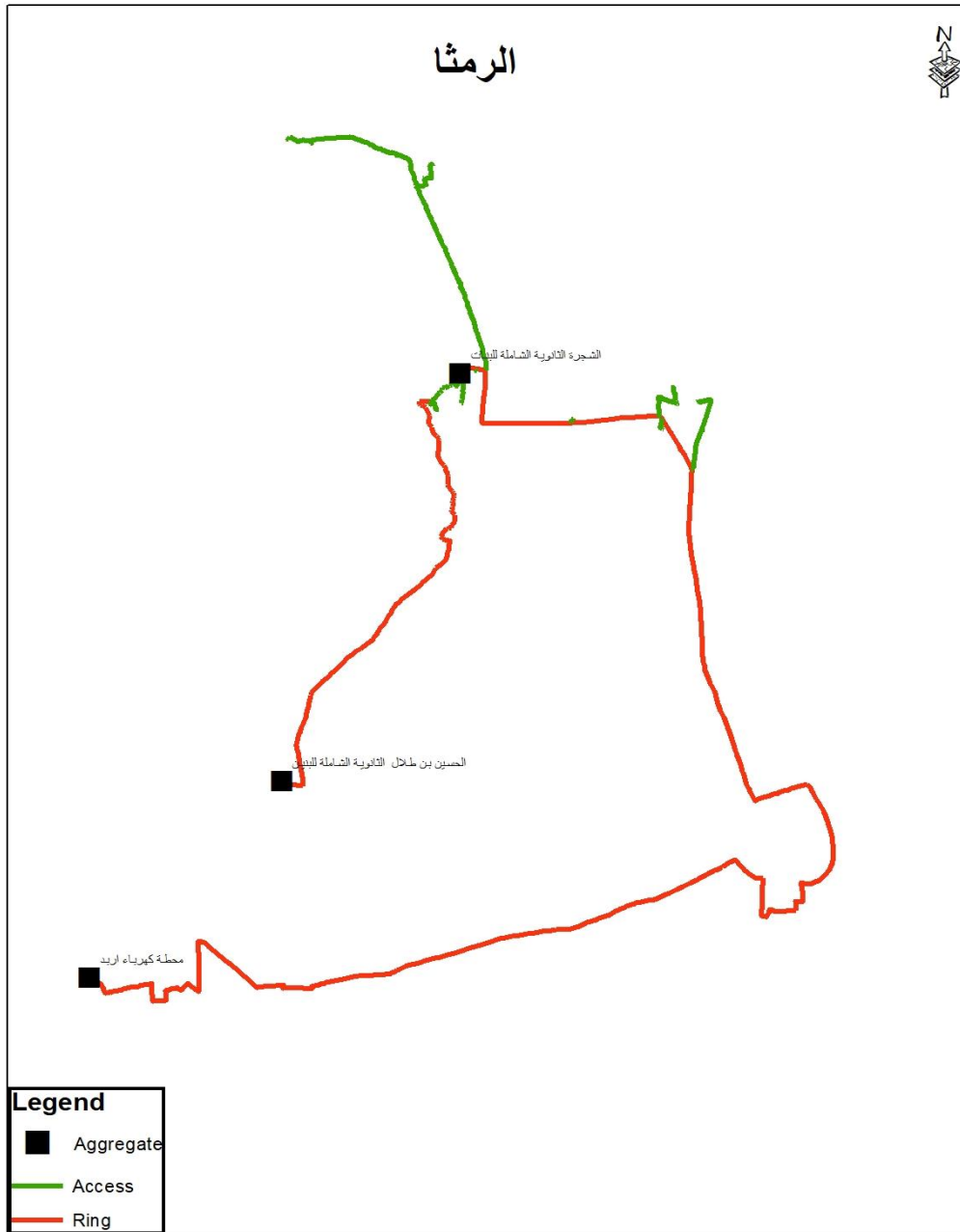

Figure 2: Module 2 Fiber Route – AL-Ramtha

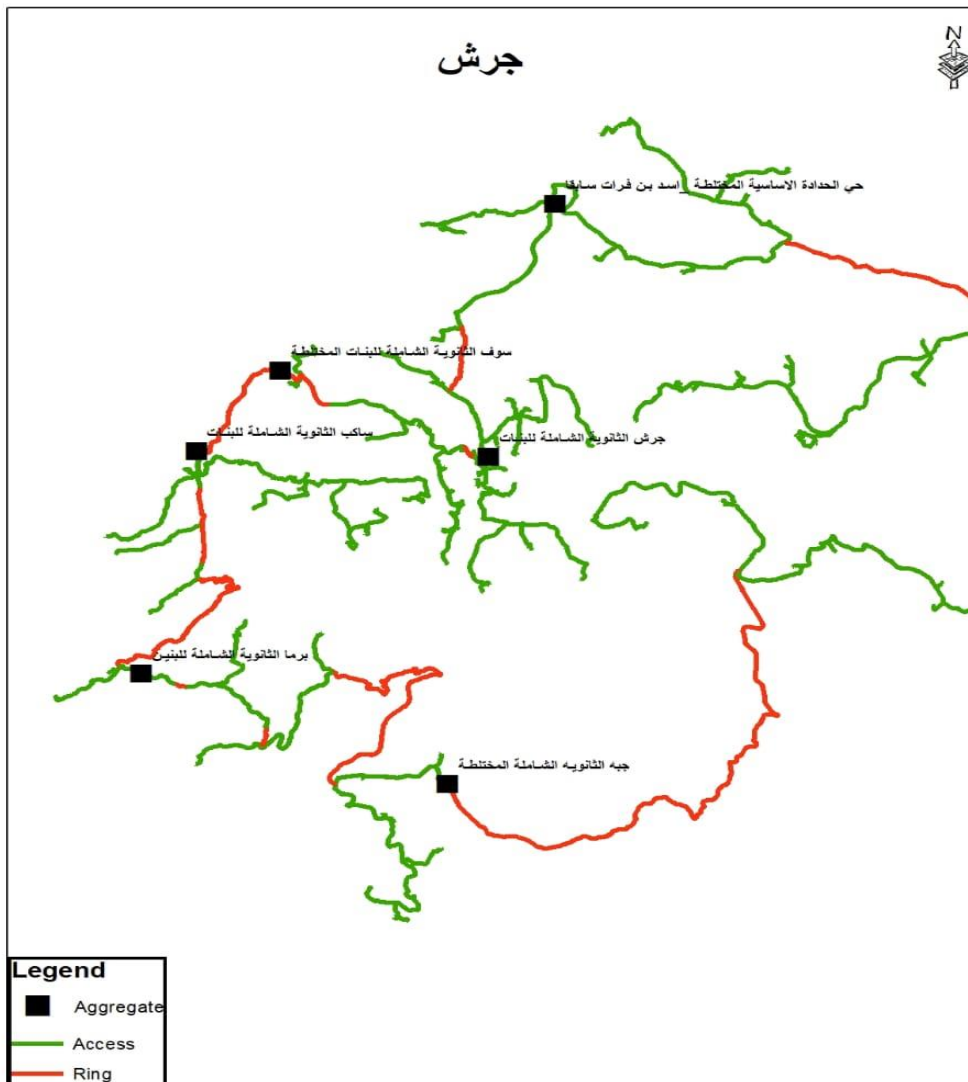

Figure 3: Fiber Route – Jarash

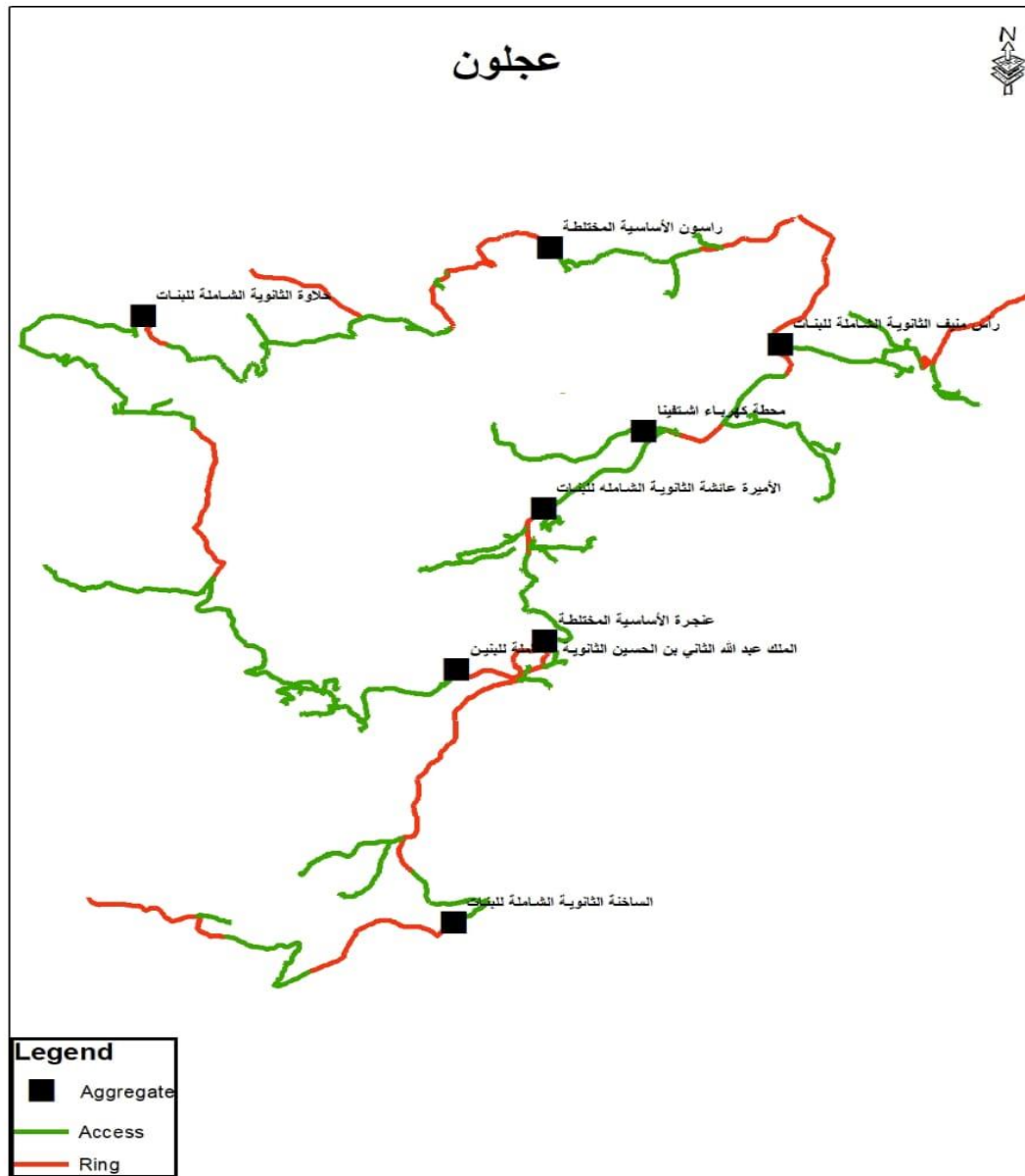

Figure 4: Fiber Route – Ajloun

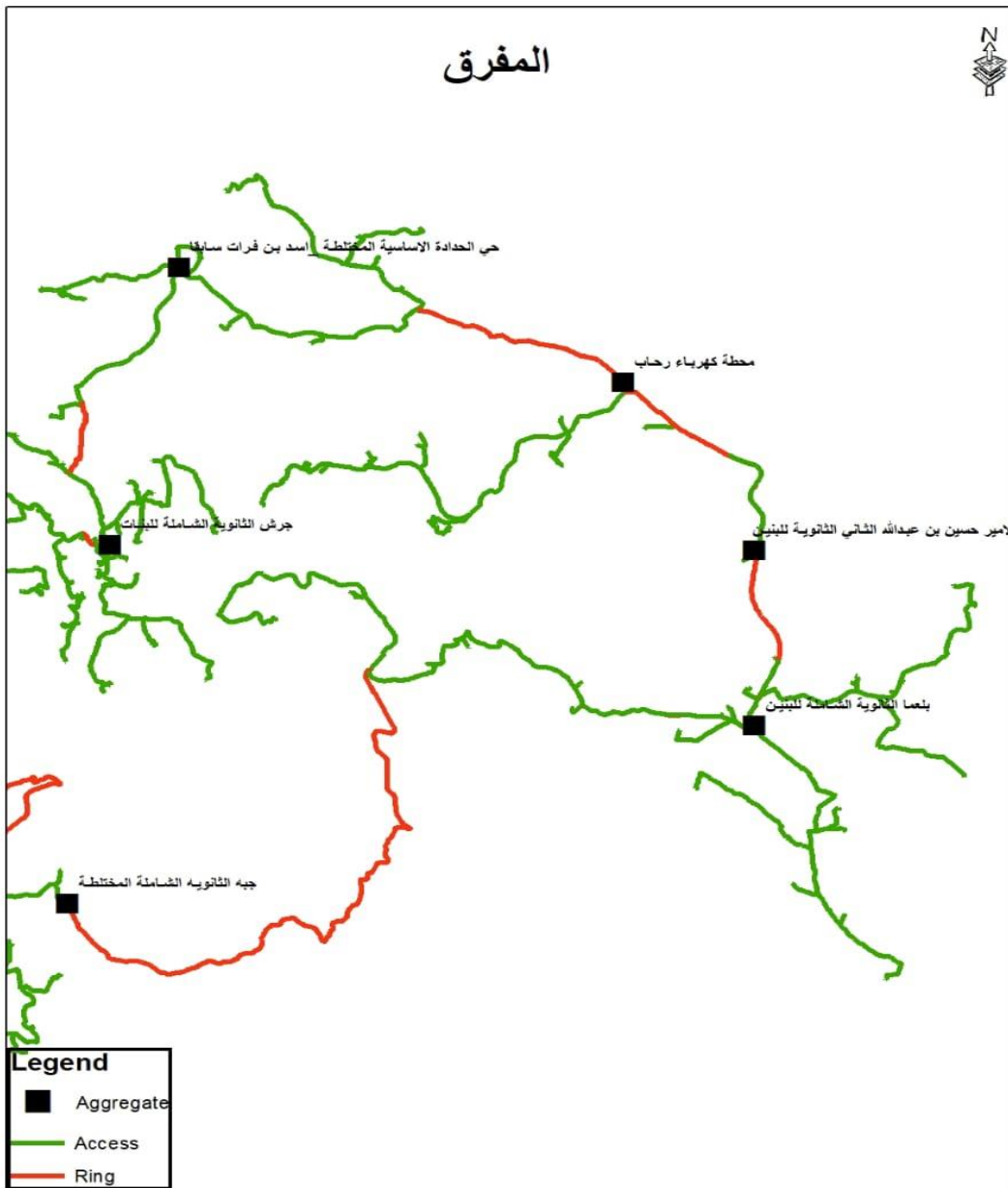

Figure 5: Fiber Route – Mafraq

The fiber diagrams of the optical network are shown in figures above. They consist of Five structures to interconnect aggregate points in every governorate. At each aggregate point multiple optical fibers connect the surrounding schools & entities in access network. This networks were implemented with conventional Duct or ADSS technology.

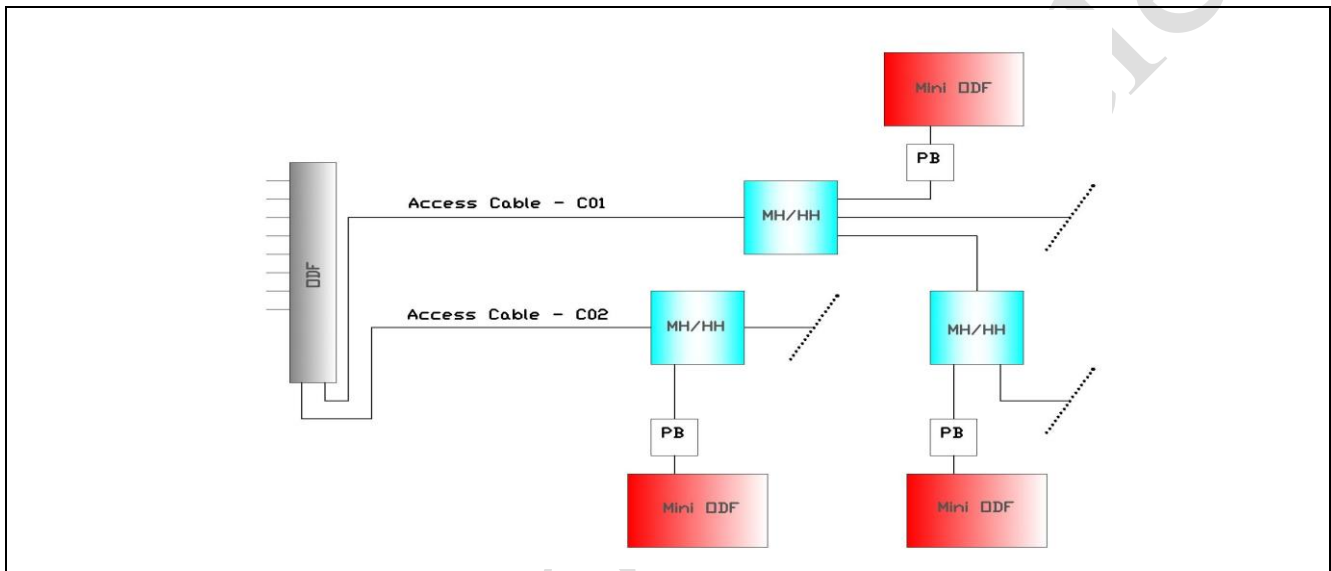

Figure 6: Connection between Aggregate Point to the Entities - Access Network

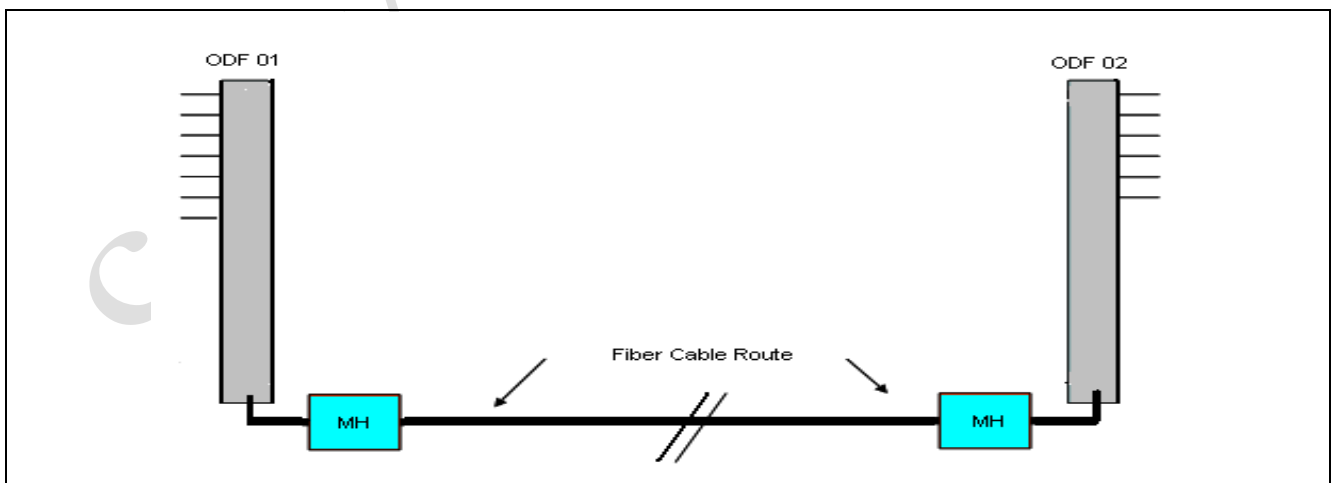

Figure 7: Connection between Aggregate Point to Aggregate Point - Ring Network

- With regard to routes transferring, fiber cuts, and Connecting new entities, the contractor may also recommend the alternate routes approved by the MODEE and comply with all authorized stakeholder's requirements and conditions (Electrical companies, Municipalities, Ministry of Public works and Housing (MPWH), ...etc.) when needed.
- All Civil and Fiber works either repairing fiber cuts, ADSS cable transferring works, connecting new entities, or removed cables must be carried out after full coordination with all authorized stakeholders and Irbid District Electricity Company (IDECO)), or Electricity Distribution Company (EDCO), and after getting all required approvals to accomplish all needed works .

This scope of work describes the existing Network as per the below technologies:

1. ADSS cables installed on existing live electrical poles: (medium and low voltage distribution power networks) as per the MODEE's agreement with the concerned authority (Electrical Companies), with all related accessories and fittings (example: ODF, Aerial splicing enclosures, splicing boxes and optical patch panels, pigtails, etc...), splicing of the cables, and end-to-end testing of installed optical network. Sufficient spare fiber cable shall be installed within selected poles.

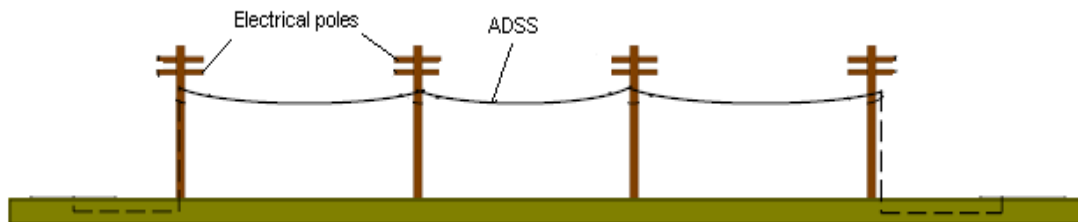

Fig (8) : ADSS Cables hanged on existing electrical poles

2. In-Duct Optical Fiber cables installed in a UPVC ducts in a trenches with all related accessories and fittings (example : ODF, splicing enclosures, splicing boxes and optical patch panels, pigtails, etc...), splicing of the cables, and end-to-end testing of installed optical network. Sufficient spare fiber cable shall be installed within selected manholes.
3. Two or Four , (1 ¼ inch) UPVC sub ducts installed inside ONE (4 inch) UPVC main duct in the trenches between manholes, hand holes and pull boxes with all required civil works, including manholes, hand holes, pull-boxes and accessories, ... etc.) as per specifications.

The trench shall be excavated and backfilled in accordance with the drawings shown below in Annex C.

The total amount of fiber and related civil works are divided into the following lots according to the technologies to be used:

Lot #	Technology	Total existing Length In North Area (Irbid, North Ghour, Jarash, Ajloun, and Mafraq)
1	ADSS Cables (On Poles)	360 Km
2	In Duct Cables	712 Km
3	Civil works (Trenches)	471 Km

copy not for sale

2. WORKS REQUIREMENTS

2.1. GENERAL

The bidder shall provide a proposal for all the works stated in the “Scope of work” and the “RFP Document”.

2.2. WORKS SERVICES

- 2.2.1. The Contractor shall submit a Signed Service-Call Report to be sent to MODEE immediately following every call out, indicating the time of call out visit, cause, remedial action taken and the time that the service was restored for every works (fiber cuts or route transfer) .
- 2.2.2. The Contractor's Response time and Resolution time shall comply with time required in the SLA under Annex J. Response time is defined by the time that elapses between the reporting of a fault and the personnel arriving where the faulty equipment is located as per the SLA Annex J. while Resolution time is defined by the time that elapses between end of response time and the end of time to complete all works (fiber cuts, route transfer, or connecting new entities) defined in the SLA annex.
- 2.2.3. Manpower Plan shall demonstrate the Contractor's committed resource level available for all types of activities to be carried out within works duration (fiber cuts, route transfer, or connecting new entities). Such plan shall be submitted in the offer.
- 2.2.4. The contractor shall keep the MODEE updated after starting the works.
- 2.2.5. The Contractor shall coordinate with the all related stakeholders and carry out safety requirements for the fiber cable installation and repairing in accordance with requirements & regulations.
- 2.2.6. It shall be the responsibility of the contractor to clean the Site from all surplus materials, rubbish, temporary works of every kind. and leave work site clean according to MODEE’s Engineer instructions.

2.3. SLR (SERVICE LEVEL REQUIREMENTS)

The Contractor in his proposal shall comply with the attached SLA in Annex J.

2.4. REQUIREMENTS & INSTRUCTIONS

- 2.4.1. Staff and needed equipment items should be determined by the contractor and should be available to comply with the SLA and shall include the following as a minimum :

- 2.4.1.1. Experienced personnel.
 - 2.4.1.2. All needed equipments to do the works.
 - 2.4.1.3. All needed equipments to do tests and report them to the ministry.
 - 2.4.1.4. All needed equipments, materials and machines to execute the civil or fiber works including the ADSS cables.
- 2.4.2. The contractor shall submit for the Engineer's approval samples and specification documents, datasheets & catalogues for all components of the passive optical fiber network upon receipt of the OTP (Order to proceed). No works can commence prior to receipt of the approval issued by the Engineer or by delegated authority by the Engineer. All works shall apply to good engineering standards.
- 2.4.3. The Contractor is responsible for the quality of the supplied materials required for the works and shall present samples and data sheets of the materials for approval by the Engineer. (This includes optical fiber cable, pigtails enclosure, splice boxes, ODFs, shelves for ODF, optical patch panels, ADSS cable, Aerial accessories, Ducts, Duct accessories chambers, chambers covers, joints, duct labels, cover labels, Electronic Identifier, warning tape,... etc..) The supply and installation of all materials is must be done in accordance with the Required specifications. Accessories shall be purchased from the cable manufacturer or purchased from vendors specialized in manufacturing such accessories.
- 2.4.4. The contractor shall take all the necessary steps to ensure that the cable is properly packed to avoid any possible damages to the cable during transportation.
- 2.4.5. Accurate location of the fault should be determined by the contractor after MODEE's report.
- 2.4.6. The Contractor should advise MODEE as soon as possible (after checking whether the cable link or the equipment is the cause of fault). This means that the contractor representative should be able to contact the MODEE's representative even at night or during public holidays.
- 2.4.7. Repair - if necessary after digging of a trench, re-installing of cable and splicing for the In-Duct routes.
- 2.4.8. **For New Routes**, The contractor shall do the following :
- 2.4.8.1. Survey the planned path for the New Routes.
 - 2.4.8.2. Propose the final path of the route to the Engineer as shop_drawing (GIS (ESRI format and AutoCAD)) with the required base-maps and Right of way from the relevant parties, the Ministry of Public Works & Housing and Municipalities Such drawings shall be in accordance with the Specifications set forth in Annex I and should be delivered in electronic format compatible with GIS (ESRI format) on CD-ROM and hard copy with the required permits from relevant parties
 - 2.4.8.3. The Contractor will supply to the MODEE a full set of as-built drawings of the Executed Works not later than one (1) week after the work completion. Such drawings shall be in accordance with the Specifications set forth in Annex I and should be delivered in electronic format compatible with GIS (ESRI format) on CD-ROM.

2.5. OBTAINING REQUIRED PERMISSIONS

The Contractor shall provide the following services in connection with obtaining the permissions to do the works for the civil and fiber works:

- (1) The Contractor shall file, with all competent authorities, stakeholders (including Municipalities, IDECO, EDCO, NEPCO, etc...) and private (non-governmental) persons, complete and accurate applications for all permissions necessary or appropriate to obtain the permits to do the works, including splice boxes and other required ancillary equipment along the route in accordance with the legal conditions applying to the permits. All applications should be finalized in due time including Access sites connectivity. Copies of the permit applications for the whole route must be forwarded to MODEE.
- (2) The Contractor shall as soon as reasonably feasible inform MODEE of any proposed modification of the Route thereby indicating the reason for the modification, the potential consequences of the additional length or reduced length of the Route for the right of way, and the MODEE shall respond to such proposal accordingly.
- (3) The Contractor shall duly follow up on such applications and to the extent necessary or appropriate, meet with competent authorities or persons (both prior to and, if necessary, after the filing of the applications), assist at any level of the procedure (e.g. take recourse against possible refusal, etc.) and revise or file new applications as a consequence of comments or suggestions received from competent authorities, the Engineer or private landowners. The Contractor shall provide the Ministry with the permits which comprise any forms of legal co-operation (including without limitation easements, servitudes, leases, access rights) by third (non-governmental) persons and all permits, licenses and other approvals or authorizations of any municipal or administrative agency or authority (including such forms of legal co-operation, collectively, permits) necessary or appropriate to enable installing the optical fiber cable and all related telecommunications infrastructure along the route in accordance with the legal conditions applying to the permits. The permits shall meet the requirements to install fiber optic cables. The permits will enable to install splice boxes, hand-holes, etc. and fiber optic cables along the whole route. Copies of the granted permit documents shall be forwarded to the Engineer within 3 working days after receipt of the grant.

2.6. FIBER WORKS PRINCIPLES

2.6.1. General Fiber Works Principles :

- 2.6.1.1. After finishing the works, the optical attenuation between the affected termination points will be measured in accordance with the procedure and acceptance criteria of Annex H.
- 2.6.1.2. Optical time domain measurements will be carried out to verify the quality of splicing of optical fibers. This will be executed in accordance with the procedure and acceptance criteria mentioned in point-3 of Annex H.
- 2.6.1.3. Optical dispersion and PMD measurements (factory sheet) of each cable drum used for the optical network shall be presented to MODEE for verification. The acceptance criteria are specified in
- 2.6.1.4. Optical termination points should be protected by removable high quality caps.
- 2.6.1.5. Duct and cable terminations into buildings should be properly sealed and protected. Sealing should be of high quality and UV-light resistant.
- 2.6.1.6. Cable terminations or cable transitions should be clearly labelled with weather and UV-resistant labels in accordance with the fiber allocation table supplied by MODEE.
- 2.6.1.7. All ducts and fiber optics should be visibly labelled with long lasting labels, with supplying a proper references material to reflect the locations of them.

2.6.2. ADSS Fiber Works Principles:

- 2.6.2.1. It is required that the entire section between the closest two existing joints be replaced.
- 2.6.2.2. Any other repair arrangements or recommendations require MODEE's approval based on a proposed design provided by the contractor to carry out the repair.
- 2.6.2.3. All installed and repaired accessories should comply with the existing accessories installed.
- 2.6.2.4. The Contractor will install all optical fiber and optical passive components to deliver optical connectivity from termination to termination point. In addition, the Contractor will test and verify the connectivity between the optical termination points as stated in Section 2.4.
- 2.6.2.5. **ADSS Cable Hardware:**
 1. **Pass-Through Bracket (Fiber Optic Tangent):** Used as cable suspension hardware only when the angle of change, either horizontal or vertical, is less than 15° .
 2. **Armor Grip Suspension:** Used for any span length with an angle change, either horizontal or vertical, less than 30° .

3. Fiber Optic Dead-end Grip:

- A dead-end is installed at each end of the cable length to attach to the structures. Two dead ends are used at angle changes of 30° or greater, either horizontal or vertical. If the structures are in-line but have a vertical difference greater than 20° , dead ends shall be used to distribute the cable through the incline/decline.

4. Road Crossing:

Tension rods, vibration damper, poles attachments and steel tip, D-shackle with related accessories, C-thimble, helical dead ends, should be used

5. ADSS-Fittings for Span Field Lengths < 70 m

- Suspension with suspension rods and protection rods (supporting rods), ring type thimble and, Poles attachment, steel tip, D-shackle with related accessories.
- We should be always use the Vibration damper at the distance more than 45m



- Tension with helical dead end and C-thimble



6. ADSS-Fittings for Span Field Lengths 70 - 150 m

- Suspension with long span suspension rods with protection or (supporting rods), ring type thimble, and vibration damper, poles attachment and steel tip, D-shackle with related accessories



- Tension with long span helical dead end, c-thimble and vibration damper and pole attachment with related accessories

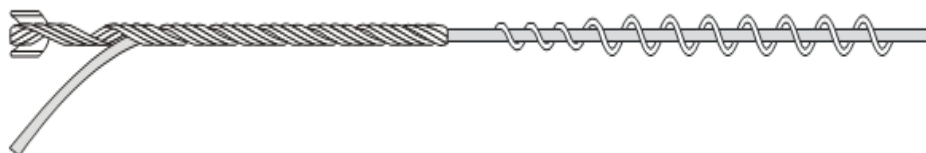

7. ADSS-Fittings for Span Field Lengths > 150 m

- long span Suspension with armor grip suspension and long span vibration damper or double vibration damper, poles attachment and steel tip, D-shackle with related accessories

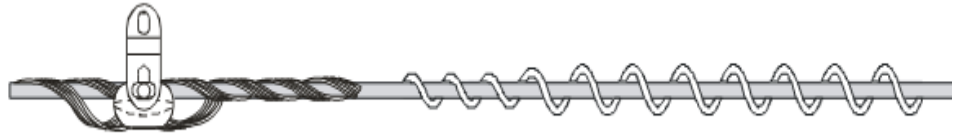

- Tension long span with D-shackle, C-thimble, helical dead end, protection rods and long span vibration damper or Double vibration damper

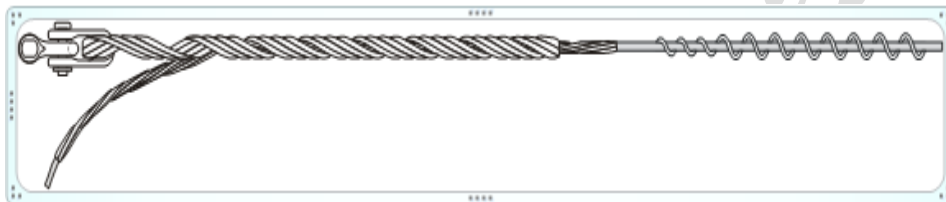

- If there is a long straight path without any angles there is no need to use suspensions, tension accessories should be used every 300 meters.
- If there are curves in the path and the angle is twenty times the cable diameter, tension accessories should be used on each curve.
- In case of cable bandings, the cable exit angles should be referenced to the Cable radius in the data sheet.
- Cable ties should be used on poles to fix the cable going down from the pole to the handhole , and its number depends on the pole type and height (Medium or Low Voltage) .

2.6.2.6. Specifications and images are stated in Annex F.

2.6.3. In Duct Fiber Works Principles:

- 2.6.3.1. The repairing includes cutting the affected cable and; replacing it with a new cable (inside the repaired ducts) and proceed with the required splicing, which could be accomplished using one or two cable splices depending on the location of the cut relative to the existing splice.
- 2.6.3.2. Any other repair arrangements or recommendations require MODEE's approval based on a proposed design provided by the contractor to carry out the repair.
- 2.6.3.3. All installed and repaired accessories should comply with the existing accessories installed.

2.6.4. Fiber Works Acceptance Testing:

The Contractor will invite the MODEE to witness the acceptance testing of the installed fiber in accordance with the SLA mentioned in Annex J. Invitation for acceptance testing should only be forwarded to the MODEE after the Contractor has successfully executed internal acceptance tests. Acceptance test will be carried out between optical termination points (ODF, patch panels) and witnessed by the appropriate representatives from the MODEE.

- 2.6.4.1. The length between optical termination points shall be verified and will be compared with the "plan-to-build"/"shop" drawings. Significant changes will be indicated and the Contractor shall specify the differences in length. Major deviations can lead to non-acceptance of the route or parts of the route.
- 2.6.4.2. The optical attenuation between the termination points shall be measured in accordance with the procedure and acceptance criteria of Annex H
- 2.6.4.3. Optical time domain measurements shall be carried out to verify the quality of splicing of optical fiber cables. This will be executed in accordance with the procedure and acceptance criteria of Annex H.
- 2.6.4.4. Optical dispersion and PMD measurements (factory sheet) of each cable drum used for the optical network shall be presented to the Employer for verification. The acceptance criteria are specified in Annex H.
- 2.6.4.5. Optical termination points should be protected by removable high quality caps.
- 2.6.4.6. Duct and cable terminations into buildings should be properly sealed and protected. Sealing should be of high quality and UV-light resistant.
- 2.6.4.7. Cable terminations or cable transitions should be clearly labeled with weather and UV-resistant labels in accordance with the fiber allocation table supplied by the Engineer.

2.7. CIVIL WORKS PRINCIPLES:

The Contractor should be aware of the specifications and regulations of North region (Irbid, North Ghour, Jarash, Ajloun, and Mafraq) Municipalities and Ministry of Public Works and Housing (MoPWH) regarding the excavations and backfilling in Asphalt or In Side-walks and their regulations should be obeyed, in addition to the following:

- (1) The Contractor will supply all labor and materials required for the Works. The Contractor is fully responsible for the quality of the supplied materials. This includes duct materials, chambers, covers, joints, cover labels, warning tape, etc.
- (2) The Contractor is fully responsible for the construction site and safety on the construction site. The Contractor shall apply for any permit required (e.g. road blockage, police permission, Jarash, Ajloun, and Mafraq Municipalities, IDECO,EDCO, NEPCO permissions and all concerned authorities) for executing the works and shall be fully compliant with the regulations of all local and governmental authorities.
- (3) The Contractor will maintain a progress report and incident report for the new executed routes and the Fiber Cuts.
- (4) The Contractor does not have the right to claim the working space excavations in addition to re-instate these excavations. The Contractor does not have the right to claim for any additional cost related to supporting the trench walls.
- (5) The execution of trench excavation for fiber optics cables 50cm wide and 100cm deep regardless of the type of the soil, and the terrain has to be re-instated to its original status. The longitudinal excavation has to be as directed by Governmental/local laws and the Supervising Engineer.
- (6) The trench constructions will be executed according to the specifications in Annex C. In case where the proposed cross section as detailed in the afore mentioned specifications, cannot be achieved and the cover of sand and pavement above the ducts is less than 60 cm, concrete protection plates or slabs should be used (concrete with a minimum cube crushing strength of 200 kg/cm² after 28 days and 20cm thickness without additional cost to MODEE) .
- (7) In case where the trench's route crosses flood's routes or valleys, concrete protection should be used (concrete with a minimum cube crushing strength of 200 Kg/cm² after 28 days and 40 cm thickness) to cover and protect the ducts from potential damages.
- (8) Backfilling with Sweileh sand to protect the pipes, not less than 30cm high.

- (9) Refill of the trench should be free of stones or other sharp objects, and should not contain polluted sand or organic materials. **The excavated material shall never be used in backfilling.** Single size material should be used on top of the Sweileh sand, in accordance with the requirements of the authorities and related specifications.
- (10) Asphalt cutting should be executed rectilinear by using special machines.
- (11) For Asphalted surfaces, a base course layer of 30cm should be applied above the single size at a compaction rate of not less than 97 % . The Asphalt layer should be not less than 7cm thick after compaction, and the compaction degree should not be less than 98% according to Marshall Test. A layer of MC-70 should be applied on the base course prior to Asphaltting, at 1.5 kg/m², to protect the base course, including the sides of the trench
- (12) The following should be applied on the complete road crossings:
- (13) Well compacted cement treated base course layer (120kg of cement/m³), or concrete layer (as required by the responsible authorities) with 40cm thickness should be applied underneath the Asphalt.
- (14) The warning tape must be of yellow color with the text given in Annex E-1 and such text is repeated every 1m. Its width should be 15cm. the material of the warning tape should be submitted to the Engineer for approved prior to the ordering process and should be placed at a distance not more than 30 cm from the finish floor level or as directed by the supervising Engineer.
- (15) A plastic rope of 6mm diameter should be installed in each duct, using different colors for each duct, for cable pulling purposes. The rope shall be one continuous peace from manhole to manhole, no knots are allowed.
- (16) Bridge crossing will be implemented after permission from the concerned authorities by installing the ducts inside 6 inch protective galvanized steel pipe along the edge of the bridge as shown in Annex D and as required by the responsible authorities.
- (17) Railways crossing will be implemented after permission from railway authorities by installing ducts inside 6 inch protective galvanized steel pipe according to the specifications of the national railways company (Jordan) as shown in Annex D.
- (18) Installation of the ducts should be executed rectilinear and in the center of trench. The ducts shall be joined together using adhesive approved by the Supervising Engineer. The ducts will be sealed at each end of chamber to avoid the entry of dirt. The identification label printed on exposed ducts every one meter and will contain the text **“MODEE-NBN”**.
- (19) Ducts shall be terminated flush to manholes, hand holes, and pull boxes; edges shall be leveled off. Ducts entering manholes, hand holes, and pull boxes shall be plugged and watertight. The plugging mechanism or material shall be readily removable to

allow for future cable installation. Ducts shall enter manholes, hand holes, and pull boxes at 90 degree to the structure's wall. After the installation of the cable inside the sub duct, the sub duct shall be tightly sealed with foam.

- (20) The trench system consists of : TWO or FOUR UPVC (1 ¼ inch) yellow ducts installed into One Main 4” Yellow UPVC duct between manholes, hand holes and pull boxes according to the specifications and drawings in Annex C.
- (21) All samples should be forwarded to the MODEE for official approval before purchasing. No construction work can commence prior to receipt of the approval issued by the MODEE. All construction works should apply to good engineering standards and in agreement with the most recent civil and architectural construction specifications issued by Ministry of Public Works and Housing and the requirements of concerned authorities.
- (22) The Contractor is fully responsible for the quality of the supplied materials. This includes duct materials, chambers, covers, joints, duct labels, warning tape, etc.
- (23) The trench should be excavated in lines as far as possible and bends should have a radius in excess of 200 cm. The trench should be leveled as much as possible and sharp objects (stones, glass, etc.) should be avoided or removed from the trench. Other cables or infrastructure should be under passed as far as possible. The security distance dictated by NEPCO, EDCO and IDECO in trenches to High Voltage power lines should be respected.
- (24) Pre-cast chambers or manholes will be installed according to the technical specifications in Annex B. The trench for the manhole will be excavated 20cm deeper at the position of chambers and this 20cm will be filled with stabilization sand. The cover of the chambers needs to be leveled with the pavement, road or surrounding terrain, and the backfill around chambers should be of single size materials. The distance between chambers/manholes should not exceed 300m.

Manholes:

- The pre-cast manholes (120cm(L)* 68cm(W)* 82cm(D)) as internal dimensions with a base and walls of 15 cm thickness, with a fair-face surface finish made from reinforced concrete with minimum cube crushing strength of 250 kg/cm² and 7Ø10 mm/m steel bars in both directions for walls and base.
- The manholes shall be equipped with terminators, galvanized pulling eyes, step, cable support , brackets, marker plates in addition to frame, steel mesh and all accessories required to fix the splicing enclosures and spare cable loop mounting.
- The two covers shall be of the heavy duty cast iron type with a label stating “MODEE-NBN”. The covers shall be lockable and bear a 40 tons load.
- In non-Urban areas : The pre-cast manholes (100cm(L)* 100cm(W)* 100cm(D)) as internal dimensions with a base and walls of 20 cm thickness, with a fair-face surface finish made from reinforced concrete with minimum cube crushing strength of 250 kg/cm² and 7Ø10 mm/m steel bars in both directions for walls, base and cover.

- The pre-cast man hole Ring (with diameter 90cm & depth 90cm) as minimum internal dimensions with a base and Wall of 10 cm thickness, with a refined surface made from reinforced concrete with a minimum cube crushing strength of 260 kg/cm², as per Annex B. The manholes shall be equipped with terminators, galvanized pulling eyes, step, cable support , brackets, marker plates in addition to frame, steel mesh and all accessories required to fix the splicing enclosures and spare cable loop mounting. The cover shall be of the heavy duty cast iron type with a label stating “MODEE-NBN”. The covers shall be lockable and bear a 40 tons load.

Hand Holes:

- The pre-cast Hand holes (91.5*46*82 cm) as internal dimensions with a base and walls of 15 cm thickness, with a fair-face surface finish made from reinforced concrete with a Minimum cube crushing strength of 250 kg/cm² and 7Ø10mm/m steel bars in both direction for walls and base.
- The Hand holes shall be equipped with terminators, galvanized cable support and bracket, marker plate, frame, and all accessories required for splicing enclosures and spare cable loop mounting..
- The cover shall be of the heavy duty cast iron type with a label stating “MODEE-NBN”. The cover shall be lockable, and bear a load 40 tons.
- The pre-cast Hand hole Ring (with diameter 60cm & depth 90cm) as minimum internal dimensions with a base and Wall of 10 cm thickness, with a refined surface made from reinforced concrete with a minimum cube crushing strength of 260 kg/cm², as per Annex B in specifications sheets

Pull Boxes:

- The pre-cast pull boxes (50*25*48.5 cm) as internal dimensions with a 5 cm thickness for the base and walls, and 10cm for the cover with a fair-face surface finish made from reinforced concrete with a Minimum cube crushing strength of 200 kg/cm².
- The cover shall be of the heavy duty cast iron type with a label stating “MODEE-NBN”.
- The pull boxes include: the cover, a marker plat (fixed on the entity's wall near the Pull Box), and finishing.

2.7.1. Civil Works Acceptance Testing

The Contractor will inform the ministry to witness the acceptance testing of the repaired route. Invitation for acceptance testing should only be forwarded to the Engineer after the Contractor has successfully executed internal acceptance tests. Acceptance test will be carried out between chambers (manholes) and witnessed by the appropriate representatives from the MODEE.

- 5.3.1 Chambers (manholes) should be of the same type as indicated in the technical specifications and drawings and approved by the Supervising Engineer. The chambers should have been installed free of dirt and water on the inside. Covers should fit correctly and should be locked. The duct feed troughs should be correctly mounted and ducts shall be terminated flush to the chamber structure. Chamber label should be marked on the inside.
- 5.3.2 The route length between chambers shall be verified and will be compared with the plan-to-build/shop drawings. Significant changes will be indicated and the Contractor shall specify the differences in length. Major deviations can lead to non-acceptance of the route or parts of the route.
- 5.3.3 The ducts shall be cleaned on the inside by blowing foam at low pressure from one chamber to the next chamber. After cleaning with the foam a mandrill will be used with a length of 150 mm and with 5 mm smaller diameter as the inside duct diameter. The mandrill should pass without any obstacles and no crossing of duct numbering should occur.
- 5.3.4 The Contractor shall execute the tests and provide an acceptance test report to the Engineer to summarize the test results from chamber to chamber for each system and duct. This acceptance report will be signed by representatives from the Contractor and the Engineer only in case of successful acceptance. The cost for this testing should be included in the bidder's unit rates and cannot be claimed separately.

2.8. ADSS CABLES TRANSFERRING:

- 2.8.1. ADSS route transferring will be according to Irbid District Electricity Company IDECO request.
- 2.8.2. IDECO or EDCO will be responsible for existing electrical poles transferring and the installation of new poles according to the agreement between MODEE and the Irbid District Electricity Company (IDECO) or Electricity Distribution Company (EDCO).
- 2.8.3. When the contractor is notified about the cable transferring by MODEE; he shall make all needed coordination with IDECO or EDCO and to get all needed permits.
- 2.8.4. Transferring the same cable and Splice enclosures should be done **(if possible)** without service interruption on the served entities. (This solution depends on the new electrical poles route and on the length of the existing cable and location of the splices).
- 2.8.5. For the new installed poles the Contractor shall supply and install new cables, splices **(If needed)** and all related fittings and cable mounting accessories.
- 2.8.6. All supplied materials to be used for installing the transferred cables should be **new** and unused, except the materials approved by MODEE's representative. .

2.9. WARRANTY

- a) The contractor shall provide a minimum one year of warranty for the manufacturer defects starting from the date of Completion of the contract
- b) The contractor warrants that the materials supplied under the contract are new, unused, and they incorporate all recent improvements in design and materials unless provided otherwise in the Contract.
- c) The contractor further warrants that all materials supplied shall have no defect, arising from design, materials, or workmanship or from any act or omission of the Supplier, that may develop under normal use of the supplied materials in the conditions prevailing in Jordan
- d) MODEE shall promptly notify the contractor in writing of any claims arising under this warranty.
- e) Upon receipt of such notice, the contractor shall, within the specified period and with all reasonable speed, repair or replace the defective materials or parts, without additional costs
- f) If the contractor, having been notified, fails to remedy the defect(s) within the period specified above in, the MODEE may proceed to take such remedial action as may be necessary, at the contractor's risk and expense and without prejudice to any other rights which the MODEE may have against the Supplier under the Contract.

3. ANNEXES

ANNEX A: DUCT AND JOINTS SPECIFICATIONS

ANNEX A: Duct and Joints Specifications

- Specifications must be available in plastic pipes (vinyl chloride) used in communications networks buried underground as follows:
- **Duct Specifications:** المواصفات الفنية لمواسير البلاستيك
- The supplied ducts must conform to the specifications below.
The color of the main and the sub ducts shall be yellow.

1 **المجال ونطاق التطبيق: Scope & Field of Application:**
تختص هذه المواصفات الخاصة بمواسير البلاستيك غير الملدن (متعدد كلوريد الفينيل) ذات المقاس الاسمي (1.25inch و 4 inch) والمستخدمه بمشاريع شبكات كوابل الاتصالات المدفونة تحت الأرض.

2 **الخواص: Characteristics:**
يجب أن يتوفر في المواسير البلاستيكية (متعدد كلوريد الفينيل) المستخدمة في تمديدات شبكات الاتصالات المدفونة تحت الأرض ما يلي:

أ. مواد التصنيع: Materials:
(1) أن تصنع أساساً من متعدد فلوريد الفينيل غير الملدن (UPVC).
(2) أن لا تحتوي على أية إضافات عدا إضافة اللون والإضافات الضرورية لتسهيل عملية تصنيع المواسير لانتاج مواسير سليمة ومعتمة ذات أسطح ناعمة وذات متانة ميكانيكية جيدة (وقد يضاف إليها مرتجعات نظيفة من نفس عملية التصنيع ونفس المنتج وتفي بمتطلبات هذه المواصفة ولا يجوز استعمال أي مرتجعات أخرى).

ب. المظهر والحالة العامة: Appearance:
(1) أن تكون جدران المواسير مستقيمة وذات مقاطع دائرية ولون اصفر.
(2) أن تكون جدران الأنابيب والأسطح الداخلية والخارجية ناعمة خالية من التشققات والشروخ والتجاعيد الحادة الأطراف والبقع والفراغات أو أية عيوب أخرى أو مواد غريبة (ويسمح بالتجاعيد الخفيفة المنبسطة).

ج. الكثافة: Density:
أن لا تقل كثافة المواسير عن 1.35 جم/سم³ ولا تزيد عن 1.45 جم/سم³ عند درجة حرارة 23 درجة مئوية.

د. الأبعاد والتفاوتات: Dimensions and Tolerances:
(1) أن يكون الطول الفعال (بدون المفة) للماسورة 6 متر وألا يتعدى التفاوت في الطول على (صفر – 30) مم.
(2) أن يكون الحد الأدنى للأقطار الخارجية ولسمك الجدران والتفاوتات كما هو موضح بالجدول رقم (1) و (2).

جدول رقم (1)

القطر (مم)		السماعة (مم)		المقاس الاسمي
الحد الأعلى	الحد الأدنى	الحد الأعلى	الحد الأدنى	
32.2	32	2.2	1.8	32 مم
110.3	110	3.8	3.2	110 مم

جدول رقم (2)

السماعة (مم)		طول المفة (مم)		المقاس الاسمي
الحد الأعلى	الحد الأدنى	الحد الأعلى	الحد الأدنى	
2.2	1.8	88.0	80.0	32 مم
3.8	3.2	121	110	110 مم

(3) يجب أن يكون طرف الأنبوب الخالي من المفة مشطوفاً Beveled لمسافة 3مم على السطح الداخلي للأنبوب .

هـ. مقاومة الصدم: **Impact Resistance** .
 أن تجتاز المواسير اختبار الصدم عند درجة حرارة 20 درجة مئوية ولا تزيد النسبة المئوية المكسورة على 10% من مجموعة العينات.

- The joints for these ducts must fit the exact inside and outside diameter and must be full waterproof.

ANNEX B: CHAMBERS SPECIFICATIONS

Prefabricated Manholes with Magnetic Metallic Cover

The manholes (120*68*82 cm) as minimum internal dimensions with a base of 15 cm thickness, with a refined surface made from reinforced concrete with fracture strength of 250 kg/cm². The manholes shall be equipped with terminators, galvanized pulling eyes, step, cable support and brackets, marker plates, frame, steel mesh and complete hardware package. The two covers shall be of the heavy type with a label stating “MODEE-NBN”. The covers shall be both lifting lock and bears 40 ton .

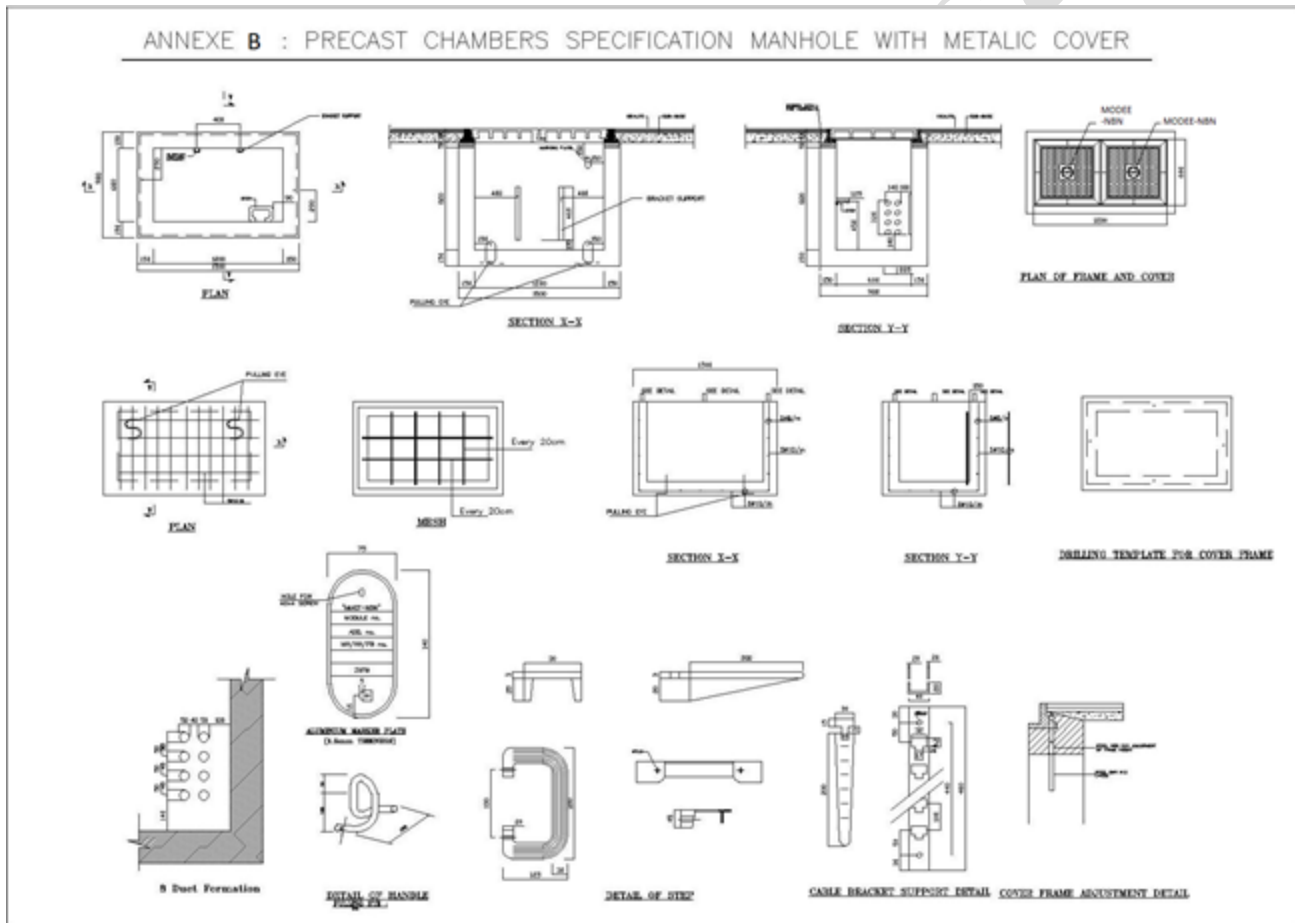

Manhole Specifications & Dimensions

Prefabricated Handholes with Magnetic Metallic Cover

The hand holes (91.5*46*82 cm) as minimum internal dimensions with a base of 15 cm thickness, with a refined surface made from reinforced concrete with fracture strength of 250 kg/cm². The hand holes shall be equipped with terminators, galvanized pulling eyes, cable support and bracket, marker plate, frame and complete hardware package. The cover shall be of the heavy type with a label stating “MODEE- NBN”. The cover shall be lifting lock. And bears 40 ton

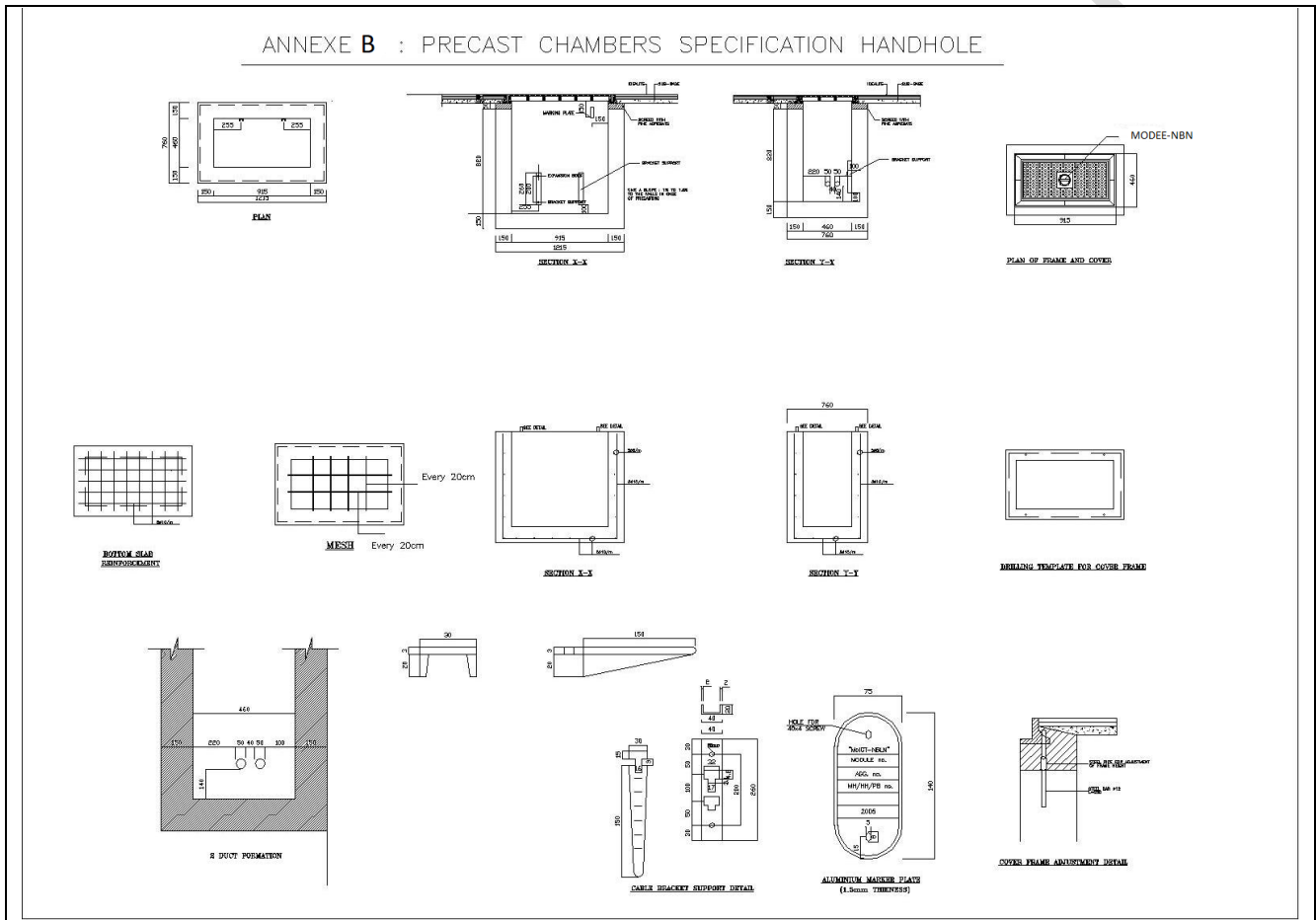

Pull Boxes

The pull boxes (50*25*48.5 cm) as minimum internal dimensions with a base of 10 cm thickness, with a refined surface made from reinforced concrete with fracture strength of 250 kg/cm². The cover shall be of reinforced concrete type. The pull boxes include: the cover, a marker plat (fixed on the entity's wall near the Pull Box), and finishing.

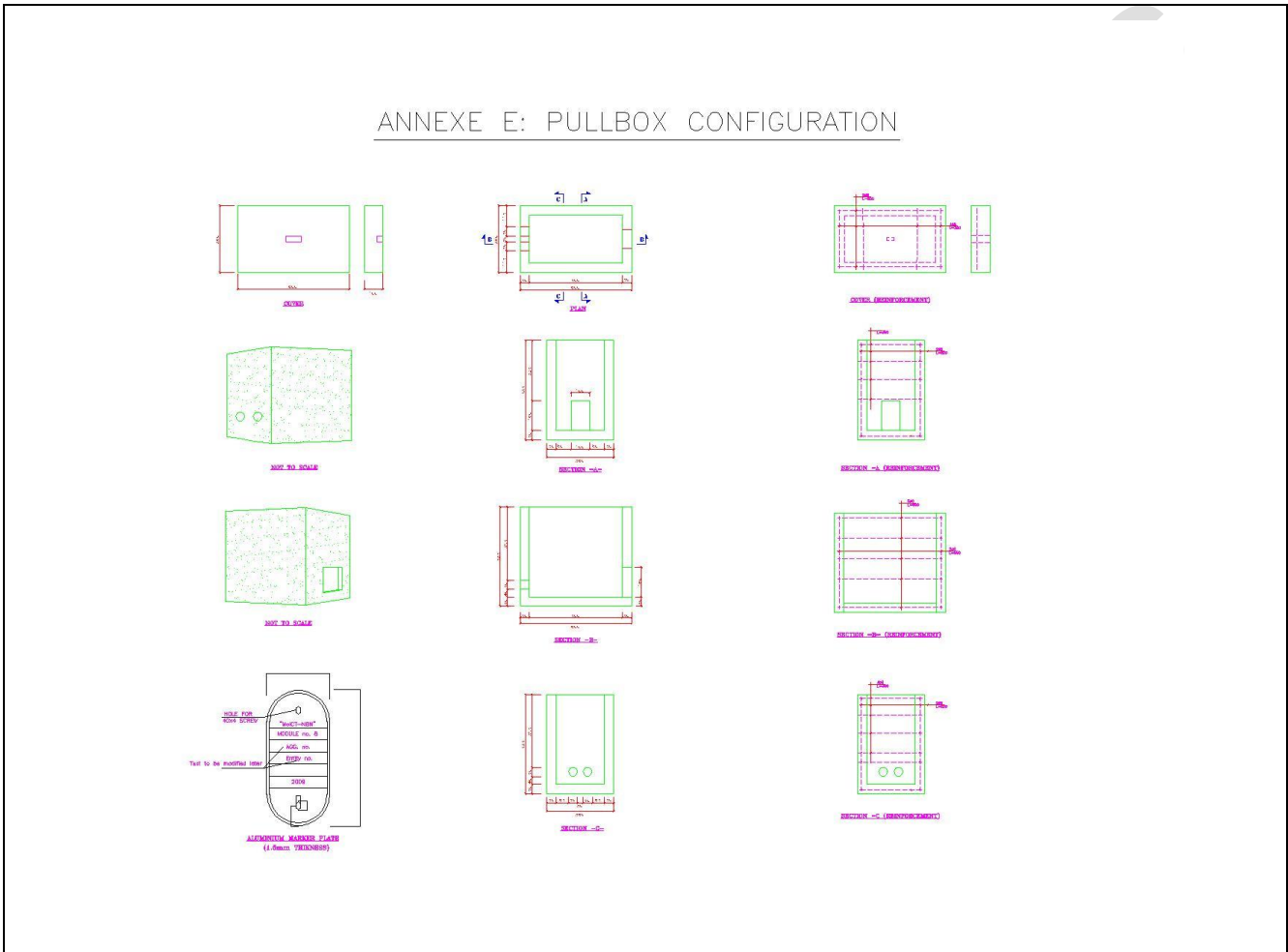

Pull box Specifications & Dimensions

ANNEX C: TRENCH SPECIFICATIONS

The trench shall be excavated and backfilled in accordance with the drawing below and the descriptions as provided in the bill of quantities.

The micro Trench shall be excavated and backfilled in accordance with the drawing below and the descriptions as provided in the bill of quantities and the upper layer(7cm) shall be backfilled with Asphalt or concrete class A according to the specifications of the MPWH and the responsible authorities.

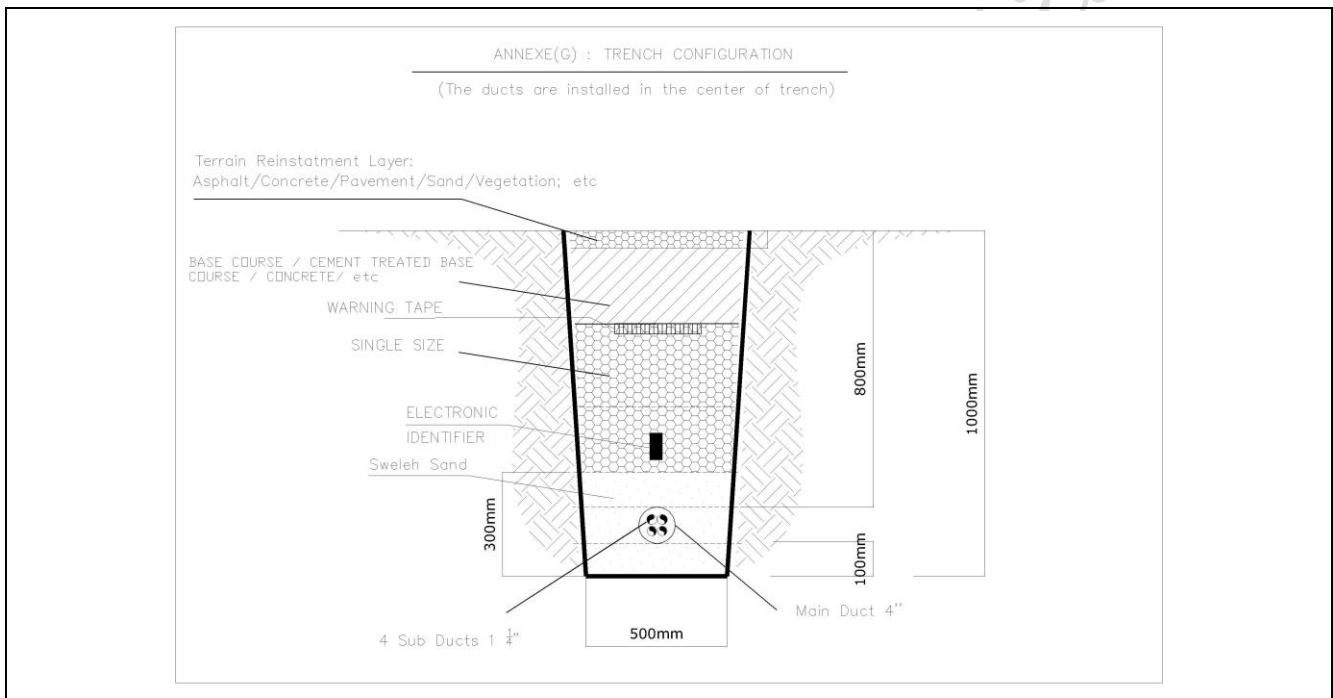

Trench Specifications for Four ducts inside one main duct

UNION ASPHALTED/TILED AREA
(15*50)cm ASPHALTED/TILED AREA

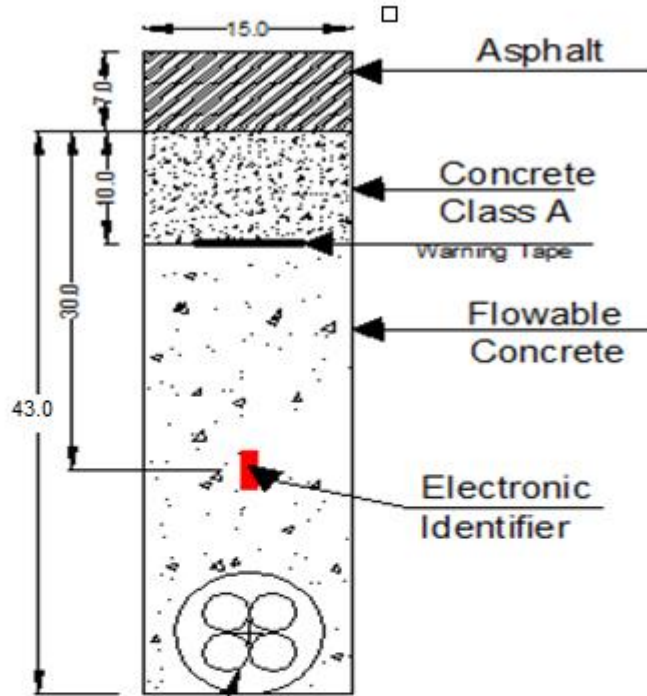

1*4" MAIN DUCT
4*1.25" SUB DUCT

حفرية بأبعاد 15 سم * 50 سم
ماسورة عدد 1 في مناطق اعادة وضع اسفلت / بلاط

(15*50) Cm Asphalted / Tiled Area

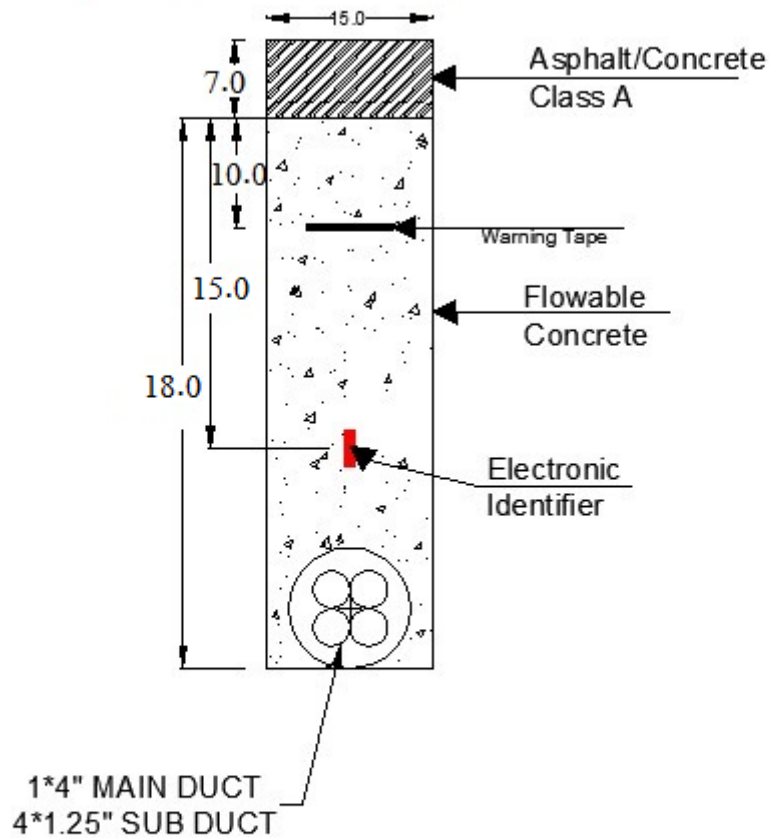

حفرة بأبعاد 15 سم * 50 سم

ماسورة عدد 1 في مناطق اعادة وضع اسفلت / بلاط

micro trench (15*50)cm Specifications for 4 sub ducts inside 1 main duct

(15*80)cm ASPHALTED/TILED AREA

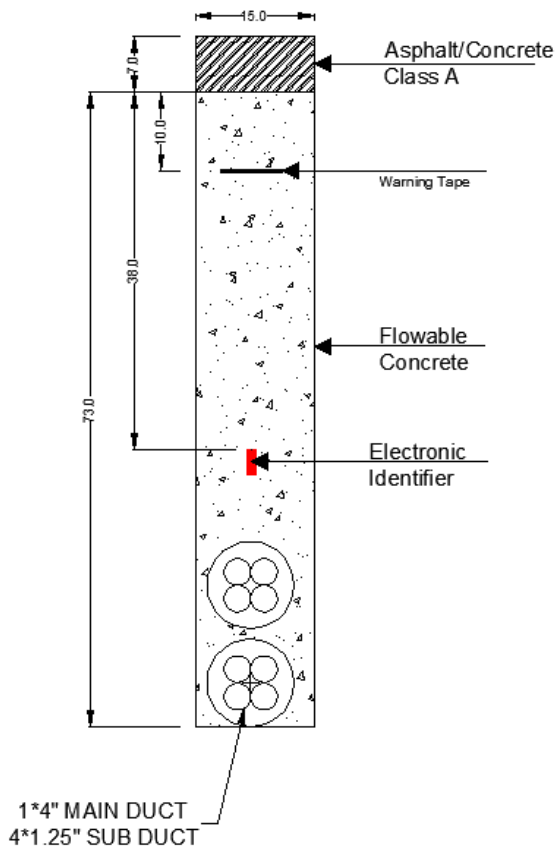

(15*80)cm ASPHALTED/TILED AREA

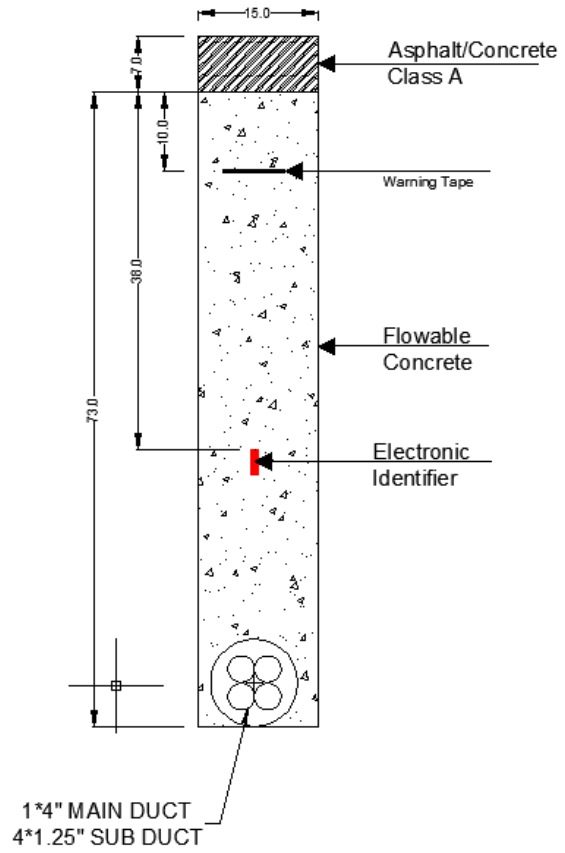

حفرة بأبعاد 15سم*80 سم
ماسورة عدد ٢ في مناطق اعادة وضع اسفلت / بلاط

حفرة بأبعاد 15سم*80 سم
ماسورة عدد ١ في مناطق اعادة وضع اسفلت / بلاط

Micro trench (15*80)cm Specifications for 1 main duct and 2 main ducts

ANNEX D: ROUTE CROSSING

The route crossing shall be implemented in accordance with the drawings below and the descriptions as provided in the specification.

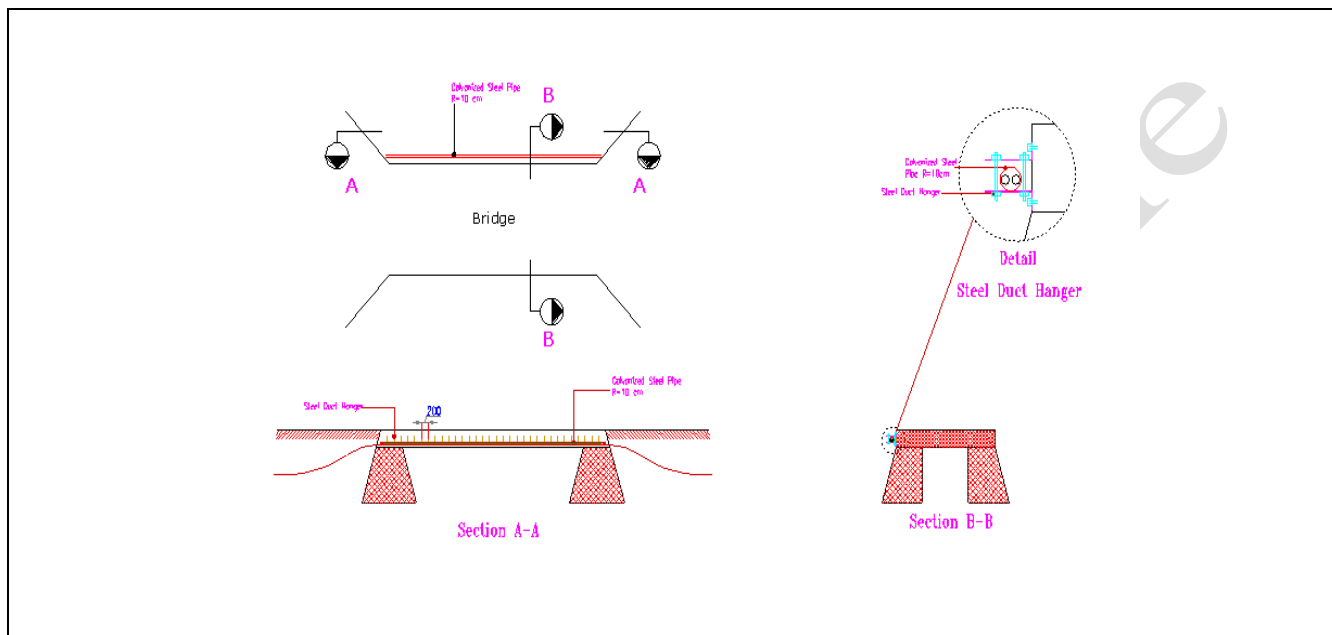

Bridge Crossing Details

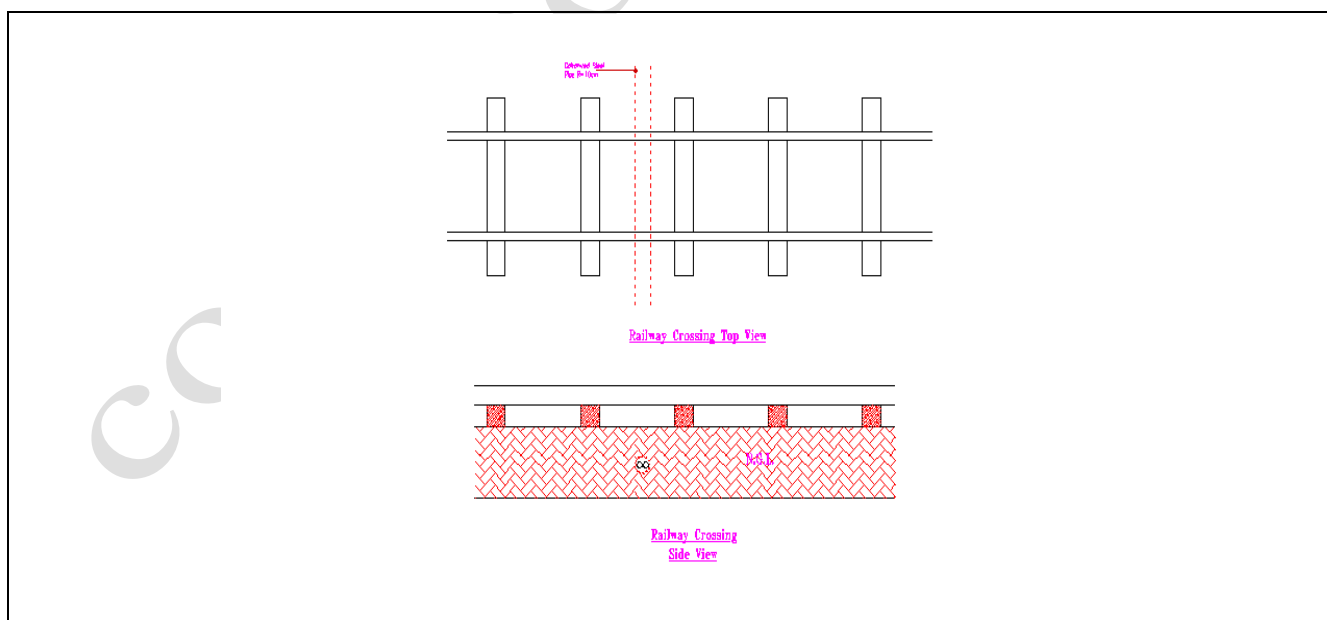

Railway Crossing Detail

ANNEX E-1: WARNING TAPE:

إنتبه !

كوابل ألياف ضوئية

(CAUTION ! FIBER OPTIC CABLES)

وزارة الإقتصاد الرقمي والريادة

MINISTRY OF DEE

إتصل بالمهندس (0800-22045) CALL ENGINEER

يمكن الإتصال من أي خط أرضي أو خلوي

copy no

ANNEX E-2: ELECTRONIC IDENTIFIERS:

Electronic Identifiers shall be installed over proposed underground networks being Water and Waste Water Utilities, and Telecommunication Utilities according to the following specs:

Specifications:

- The design and construction of the Electronic Identifier shall be rugged, reliable, and durable.
- The cross sectional area be small in order to fit in tight places.
- The following is the required specifications:

Utility	Telecommunication
Color	Orange
Frequency	101.4 KHZ
Accuracy	± 1 %
Depth Range	60 – 150 cm
Operating Temp. ċ	-40 to +70
Storage Temp. ċ	-40 to +85
RLC Circuit	Core of the inductor should be a ferrite core
Housing	Rugged, with a water proof insulating material to protect the RLC circuit in case the outer casing is broken
Life Expectancy	45 years min.
Field Trials	Required, and cannot be conducted during the execution of the project. Any product to be suggested for use should pass a field trial test where a sample of the product is placed in position for 3 months, and tested for operation on monthly basis.

Samples shall be submitted by the contractor to be approved by the Engineer without any additional costs.

Installation:

Electronic Identifiers shall be installed in the following both manners:

Vertically:

Within the top of the soft backfill layer (bedding), over the utility at a depth not exceeding 90 cm from the surface of the ground.

Horizontally:

One identifier every 6 meters max.

Electronic Identifier Locator shall be provided to the MODEE as part of the project deliverables to be used to verify that all identifiers have been installed properly.

Copy not for sale

FIBER SPECIFICATIONS:

ANNEX F-1: TECHNICAL SPECIFICATIONS OF OPTICAL FIBER CABLE - DUCT TYPE

1. General Considerations

The cable shall be designed for applications inside protective UPVC sub-duct of 32 mm diameter.

This specification describes the cable design, properties of the fibers and the cable, the testing and the quality assurance during manufacturing, the final acceptance tests and the packaging.

Single mode optical fiber cables which are optimized for use in both wave lengths windows of 1310 nm and 1550 nm are required. The optical fiber cables shall meet the requirements stated in ITU-T Rec. G.652 D.

The cable shall be new, unused and of current design and manufacture.

The identification label printed on cable every one meter and shall contain the text “**MODEE-NBN**”.

2. Standards

The specification refers to the following standards:

- IEC60793-1: Optical Fibers - Part 1: Generic Specification.
- IEC60793-2: Optical Fibers - Part 2: Product Specifications.
- IEC60794-1: Optical Fiber Cables - Part 1: Generic Specification.
- IEC60794-4: Optical Fiber Cables - Part 4: Sectional Specifications for OCEPL.
- EIA/TIA 598: Color Coding of Fiber Optic Cables.
- EIA/TIA 492-CAAB.

3. Fiber Characteristics

3.1. General Fiber Specifications

The fibers shall meet all requirements according to IEC 60793-2 Category B1.

All optical fibers shall be sufficiently free of surface imperfections and inclusions to meet the optical, mechanical, and environmental requirements of this specification. **Factory made optical fiber splices are not allowed.**

Each optical fiber shall consist of a SiO₂ core doped with GeO₂ and a fused SiO₂ cladding (matched clad) giving a fiber with a step profile of the refractive index.

The coating shall be easily strippable by means of a mechanical stripping tool without damaging the fibers. No chemicals shall be required.

The fibers shall be completely phosphorus free.

3.2. Optical and Mechanical Characteristics of Standard Single Mode Fibers

Single-mode Low Water Peak fiber shall be utilized in these optical fiber cables and shall meet the ITU recommendation G.652 D, "Characteristics of a Single-Mode Optical Fiber Cable".

This requirement defines standard single-mode fibers for use across a broad wavelength range including the extended band (1360 nm - 1460 nm).

These fibers shall have the specified performance and geometry values except as noted below:

Mode field diameter (1310 nm):	9.2 μm ± 0.4 μm
Mode field diameter (1550 nm):	10.4 μm ± 0.5 μm
Cladding diameter:	125 μm ± 0.7 μm
Mode field concentricity error:	≤ 0.5 μm
Cladding non circularity:	≤ 0.8 %
Refractive index profile:	step
Design:	matched cladding
Effective group index of refraction N _{eff} (at 1310nm):	1.4677
Effective group index of refraction N _{eff} (at 1550nm):	1.4682
Cut off wavelength of cabled fiber:	≤ 1260 nm
Attenuation at 1310 nm:	≤ 0.35 dB/km
Attenuation at 1383 nm:	≤ 0.35 dB/km

Attenuation at 1550 nm: ≤ 0.22 dB/km

Attenuation at 1625 nm: ≤ 0.24 dB/km

The attenuation measurements shall be made after finally winding the cable on its shipping drum. Cable ends shall then be hermetically sealed.

Each fiber in each cable delivery length shall have a zero-dispersion over the range 1300 - 1324 nm. Maximum dispersion at the wavelength 1550 nm shall not exceed 18 ps/nm.km or as per ITU-T recommendation Rec. G.652 D

3.3. Core Material

The core of the optical fiber, with a higher refractive index compared to the cladding, is made of SiO₂ (Silicon dioxide) doped with GeO₂ (Germanium dioxide).

3.4. Cladding Material

The cladding of the optical fiber is made of SiO₂ (Silicon dioxide).

3.5. Type of Primary Coating

The primary coating is made of an UV-curable acrylate. It is applied in two layers, each of a different Young's modulus. The inner layer is somewhat softer than the outer one. This make-up protects the fiber against micro bending losses and against abrasion.

3.6. Dimension of Primary Coating

The dimension of the primary coating is 245 ± 5 μ m.

The diameter of loose tube must be 2.5mm.

3.7. Mechanical Characteristics of the Primary Coating

The primary coating is easily strippable by means of a mechanical stripping tool. No chemicals shall be used.

3.8. Mechanical Characteristics of Fiber

A non-metallic central core shall be provided which may constitute the strength member designed to withstand all longitudinal stresses or its strength may be supplemented by an additional stress sharing sheath. The core shall be of a non-hygroscopic material.

Proof test stress: 8 N for 1 second; strain: 1 %.

Each optical fiber shall be proof tested by the fiber manufacturer at a minimum of 100 kpsi (0.7 Gpa).

The tube of the cable shall be able to contain 6 to 48 colored fibers. For fiber counts greater than 6, color coded binders shall be used to segregate the fibers into color coded groups. To the extent possible, colored fibers shall be segregated in groups of 12.

Fiber Color Coding:	fiber-# 1 : Blue	fiber-# 7 : Red
	fiber-# 2 : Orange	fiber-# 8 : Black
	fiber-# 3 : Green	fiber-# 9 : Yellow
	fiber-# 4 : Brown	fiber-# 10 : Violet
	fiber-# 5 : Slate	fiber-# 11 : Pink
	fiber-# 6 : White	fiber-# 12 : Turquoise

The binders of the fibers bundles shall be distinguishable by means of color coding in accordance with TIA/EIA-598-B, "Optical Fiber Cable Color Coding".

The central buffer tube shall be filled with a non-hygroscopic, non-nutritive to fungus, electrically non-conductive, homogenous gel in order to prevent water penetration and migration. The gel shall be free from dirt and foreign matter. The gel shall be readily removable with conventional nontoxic solvents.

The central metal tube shall be surrounded by a high density polyethylene (HDPE) jacket which shall have a bright color (e.g. orange, red, blue). The nominal jacket thickness shall be minimal 1 mm. The jacket shall not promote the growth of fungus.

The jacket shall be free of holes, splits, and blisters.

Cable jackets shall be marked with manufacturer's name, month and year of manufacture, sequential meter markings, a telecommunication handset symbol and "MODEE-NBN" as required by Section 350G of the National Electrical Safety Code® (NESC®), fiber count, and fiber type. The actual length of the cable shall be within +/- 1 % of the length markings. The print color shall contrast with the cable jacket. The letters must be engraved on the Cable jackets clearly, Not dimmed and the ink must be suitable for cable jacket material. The size of the marking letters shall be approximately 2.5 mm.

If the initial marking fails to meet the specified requirements (i.e., improper text statement, color, legibility, or print interval), the cable may be remarked using a contrasting alternate color. The

numbering sequence will differ from the previous numbering sequence, and a tag will be attached to both the outside end of the cable and to the reel to indicate the sequence of remarking.

The maximum pulling tension shall be 1000 N during installation (short term) and 250 N long term installed.

The shipping and storage temperature range of the cable shall be -30°C to $+70^{\circ}\text{C}$. The operating temperature range of the cable shall be -30°C to $+70^{\circ}\text{C}$. The installation temperature range of the cable shall be -5°C to $+50^{\circ}\text{C}$.

4. General Cable Performance Specifications

The cable shall fulfill the following mechanical, thermal and electrical characteristics. If applicable, during and after the tests, the attenuation shall be monitored at the operating wavelength.

4.1. Tensile Performance

The cable shall be tested in accordance with IEC 60794-1-E1. The cable shall be subjected to a load of 1000 N. No fibers shall exhibit a measurable change in attenuation after load removal.

4.2. Crush Resistance

The cable shall withstand a compressive load of 30 kN/m - 50 kN/m for duration of 15 minutes. The load shall be applied uniformly over the length of the compression plate. The cable shall be tested in accordance with IEC 60794-1-E3. No fibers shall exhibit a measurable change in attenuation after load removal.

4.3. Cable Bend

The minimum bending radius of the cable shall be more than 5 times the outer diameter. It shall be tested in accordance with IEC 60794-1-E11. After the test there shall be no change in fiber attenuation greater than the uncertainty of measurement.

4.4. Temperature Cycling

The cable shall be subjected to a minimum temperature of -30°C and a maximum temperature of $+70^{\circ}\text{C}$. The test shall be performed in accordance with IEC 60794-1-F1. The change in fiber attenuation shall not be greater than the uncertainty of measurement.

4.5. Water Penetration

A 1 m sample of the cable shall be subjected to a water penetration test according to IEC 60794-1-F5. After duration of 24 hours no water shall be detected at the open end of the cable core.

5. Testing

5.1. Type Test

The type tests given in Section 6 shall be performed on the fiber optic cable.

5.2. Factory Acceptance Test

The cable performance shall be proved by showing detailed test reports of the optical attenuation (if applicable) during and after the test and all relevant test parameters of the type test.

5.3. Routine Test

The optical attenuation coefficient as required in Section 3.2 shall be verified at 1550 nm on all production cable lengths. The test shall be performed according to IEC 60793-1-C1C (Backscattering technique).

6. Quality Assurance Provision

The manufacturer shall carry out quality inspection and keep a record of the test results to an extent agreed. The manufacturer shall also have a trace ability of the materials used, and of the production steps, used in the manufacturing of the cable to an extent agreed.

The supplier shall provide details of his quality control procedures that shall include the methodical recording of the results of production measurements.

Test result shall include the following:

1. Cable designation.
2. Number of fibers.
3. Fiber type.
4. Refractive index.
5. Drum no.
6. Length of cable.

7. Data of measurements.
8. Attenuation for every fiber at 1310 nm.
9. Attenuation for every fiber at 1550 nm.
10. Zero-dispersion wavelength for every fiber.
11. Zero-dispersion slope for every fiber.
12. Maximum and minimum value of mode field diameter of fibers in the cable.
13. Maximum and minimum value of cut-off wavelength in the cable.
14. A core-concentricity error of fibers in the cable.
15. Dispersion.
16. The test results shall be attached on the drum.

7. Packaging

Cables shall be uniformly wound with no gaps between successive turns.

Cable ends shall be effectively sealed against physical damage, the ingress of water and loss of jelly filling, opening and re-sealing being possible at least ten times.

Identification of the cable drum shall include the following parameters:

1. Name of manufacturer and year of production.
2. Cable designation and content.
3. Cable ID numbers.
4. Length of cable and start and finish mark.
5. Order no.
6. Any other useful information.

Drum size shall preferably be suitable for cable lengths of at least 3000 m as one piece. Longer pieces are preferable.

Tenderers shall state the maximum drummed cable length of each cable type offered and the size and gross weight of loaded drums.

The cables shall be supplied on a wooden drum. Each length of cable shall be wound on a separate drum.

The diameter of the drum barrel shall be large enough to prevent damage to the cable during reeling or unreeling. The diameter of the barrel shall not be smaller than 40 times the outer diameter of the cable.

The drum shall be durable and constructed such as to prevent damage to the cables during shipment and handlings.

Lags or other suitable means of protection shall be applied to the drum to prevent damage to the cables during shipment and storage. Nails and staples used in the construction of the drum must not be placed in a position where they can damage the cables. The drums shall be non-returnable.

Drums with a ramp should be used. For test purposes a length of approx. 4 - 5 m of the inner end shall be accessible.

The cable ends shall be sealed with shrinking caps and fastened tightly. A protective wrap shall be applied over the outer layer of the cable on each reel. The wrap shall be weather resistant and shall not be removed until the cable is installed.

Marking plates, containing following information shall be securely attached to the outer side on each drum flange:

- Type and size of cable.
- Cable length in meters.
- Gross weight in kilograms.
- Reel number.
- Manufacturer's name.
- Year of manufacture.
- Project name and number.
- Arrow showing roll direction.

The plates shall be made of an all-weather resistant non-corrosive material.

8. Miscellaneous

The cable manufacturer shall introduce and maintain a quality system according to ISO 9001.

All optical fibers in each manufactured length shall be tested for attenuation according to Section 5.3. The measured attenuation coefficients (in dB/km) shall be provided with each cable reel. For lengths less than one kilometer, in consideration of test limitations, values that are within 0.05 dB of the specified end to end attenuation may be reported as the specification limit coefficient.

At the request of the Employer, the cable manufacturer shall provide installation procedures, all necessary equipment for the installation process and technical support concerning the items contained in this specification.

copy not for sale

ANNEX F-2: TECHNICAL SPECIFICATIONS OF OPTICAL FIBER CABLE - AERIAL TYPE

1. General Considerations

All aerial optic fiber cables shall be of All-Dielectric Self Supporting (ADSS) type and have the configuration shown below. The aerial optic fiber cable shall be designed for stable optical performance at extreme temperatures where thermal expansion or contraction is negligible over a wide temperature range. The cable shall be ready to be installed on medium and low voltage electricity poles. The cable shall be installed on utility structures without interrupting power.

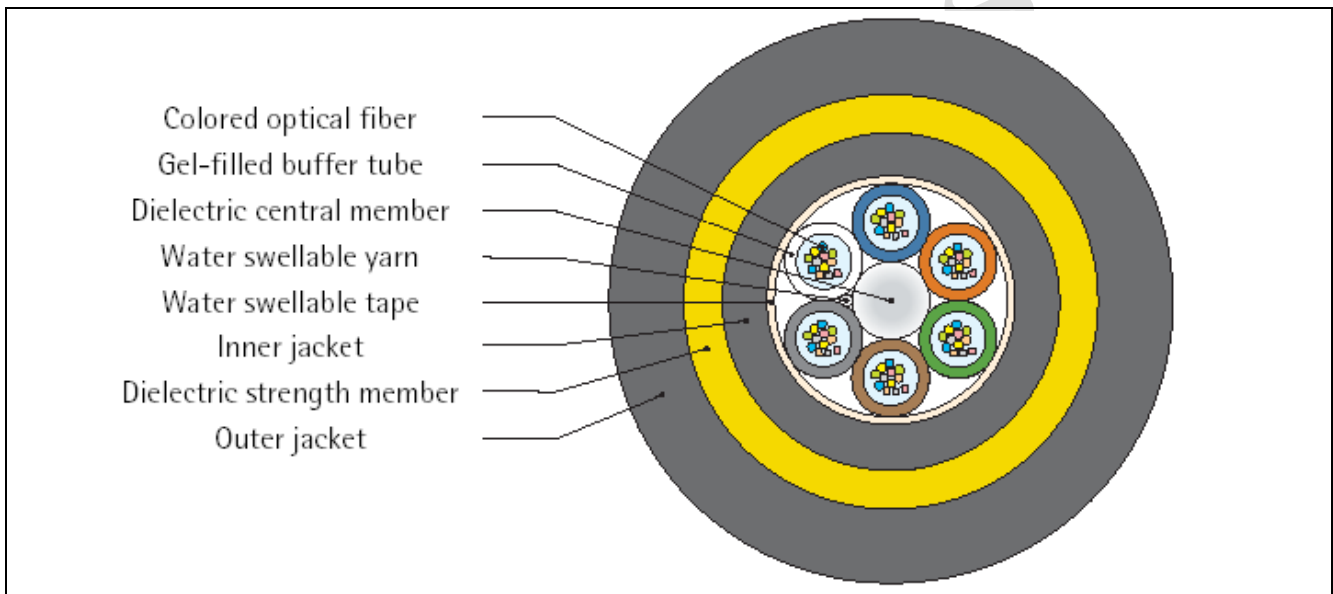

All-Dielectric Self Supporting Optic Fiber Cable Components

This specification describes the cable design, properties of the fibers and the cable, the testing and the quality assurance during manufacturing, the final acceptance tests and the packaging.

Single mode optical fiber cables which are optimized for use in both wave lengths windows of 1310 nm and 1550 nm are required. The optical fiber cables shall meet the requirements stated in ITU-T Rec. G.652 D.

The cable shall be new, unused and of current design and manufacture.

2. Standards

The specification refers to the following standards:

- IEC60793-1: Optical Fibers - Part 1: Generic Specification.
- IEC60793-2: Optical Fibers - Part 2: Product Specifications.
- IEC60794-1: Optical Fiber Cables - Part 1: Generic Specification.
- IEC60794-4: Optical Fiber Cables - Part 4: Sectional Specifications for OCEPL.
- EIA/TIA 598: Color Coding of Fiber Optic Cables.

3. Fiber Characteristics

3.1. General Fiber Specifications

The fibers shall meet all requirements according to IEC 60793-2 Category B1.

All optical fibers shall be sufficiently free of surface imperfections and inclusions to meet the optical, mechanical, and environmental requirements of this specification. **Factory made optical fiber splices are not allowed.**

Each optical fiber shall consist of a SiO₂ core doped with GeO₂ and a fused SiO₂ cladding (matched clad) giving a fiber with a step profile of the refractive index.

The coating shall be easily strippable by means of a mechanical stripping tool without damaging the fibers. No chemicals shall be required.

The fibers shall be completely phosphorus free.

3.2. Optical and Mechanical Characteristics of Standard Single Mode Fibers

Single-mode Low Water Peak fiber shall be utilized in these optical fiber cables and shall meet the ITU recommendation G.652 D, "Characteristics of a Single-Mode Optical Fiber Cable".

This requirement defines standard single-mode fibers for use across a broad wavelength range including the extended band (1360 nm - 1460 nm).

These fibers shall have the specified performance and geometry values except as noted below:

Mode field diameter (1310 nm):	$9.2 \mu\text{m} \pm 0.4 \mu\text{m}$
Mode field diameter (1550 nm):	$10.4 \mu\text{m} \pm 0.5 \mu\text{m}$
Cladding diameter:	$125 \mu\text{m} \pm 0.7 \mu\text{m}$
Mode field concentricity error:	$\leq 0.5 \mu\text{m}$
Cladding non circularity:	$\leq 0.8 \%$
Refractive index profile:	step
Design:	matched cladding
Effective group index of refraction N_{eff} (at 1310nm):	1.4677
Effective group index of refraction N_{eff} (at 1550nm):	1.4682
Cut off wavelength of cabled fiber:	$\leq 1260 \text{ nm}$
Attenuation at 1310 nm:	$\leq 0.35 \text{ dB/km}$
Attenuation at 1383 nm:	$\leq 0.35 \text{ dB/km}$
Attenuation at 1550 nm:	$\leq 0.22 \text{ dB/km}$
Attenuation at 1625 nm:	$\leq 0.24 \text{ dB/km}$

The attenuation measurements shall be made after finally winding the cable on its shipping drum. Cable ends shall then be hermetically sealed.

Each fiber in each cable delivery length shall have a zero-dispersion over the range 1300 - 1324 nm. Maximum chromatic dispersion at the wavelength 1330 nm shall not exceed 3.2 ps/nm.km or as pair ITU-T recommendation G.652 D.

3.3. Core Material

The core of the optical fiber, with a higher refractive index compared to the cladding, is made of SiO₂ (Silicon dioxide) doped with GeO₂ (Germanium dioxide).

3.4. Cladding Material

The cladding of the optical fiber is made of SiO₂ (Silicon dioxide).

3.5. Type of Primary Coating

The primary coating is made of an UV-curable acrylate. It is applied in two layers, each of a different Young's modulus. The inner layer is somewhat softer than the outer one. This make-up protects the fiber against micro bending losses and against abrasion.

3.6. Dimension of Primary Coating

The dimension of the primary coating is $250 \pm 15 \mu\text{m}$.

The diameter of loose tube must be 2.5mm.

Mechanical Characteristics of the Primary Coating

The primary coating is easily strippable by means of a mechanical stripping tool. No chemicals shall be used.

3.7. Mechanical Characteristics of Fiber

A nonmetallic central core shall be provided which may constitute the strength member designed to withstand all longitudinal stresses or its strength may be supplemented by an additional stress sharing sheath. The core shall be of a non-hygroscopic material.

Proof test stress: 8 N for 1 second; strain: 1 %.

Each optical fiber shall be proof tested by the fiber manufacturer at a minimum of 100 kpsi (0.7 GN/m²).

The loose buffer tube of the cable shall be able to contain 6 to 48 colored fibers. For fiber counts greater than 6, color coded binders shall be used to segregate the fibers into color coded groups. To the extent possible, colored fibers shall be segregated in groups of 12.

Fiber Color Coding:

fiber-# 1 : Blue	fiber-# 7 : Red
fiber-# 2 : Orange	fiber-# 8 : Black
fiber-# 3 : Green	fiber-# 9 : Yellow
fiber-# 4 : Brown	fiber-# 10 : Violet
fiber-# 5 : Slate	fiber-# 11 : Pink
fiber-# 6 : White	fiber-# 12 : Turquoise

The loose buffer tube of the fibers shall be distinguishable by means of color coding in accordance with TIA/EIA-598-B, "Optical Fiber Cable Color Coding".

The buffer tube shall be filled with a non-hygroscopic, non-nutritive to fungus, electrically non-conductive, homogenous gel in order to prevent water penetration and migration. The gel shall be free from dirt and foreign matter. The gel shall be readily removable with conventional nontoxic solvents.

The central strength member shall be surrounded by a high density polyethylene (HDPE) jacket which shall have a bright color (e.g. orange, red, blue). The nominal jacket thickness shall be minimal 1 mm. The jacket shall not promote the growth of fungus.

The jacket shall be free of holes, splits, and blisters. The cable shall have two jackets, i.e. inner and outer jackets.

Cable jackets shall be marked with manufacturer's name, month and year of manufacture, sequential meter markings, a telecommunication handset symbol and "MODEE-NBN" as required by Section 350G of the National Electrical Safety Code[®] (NESC[®]), fiber count, and fiber type. The actual length of the cable shall be within +/- 1 % of the length markings. The print color shall contrast with the cable jacket. The letters must be engraved on the Cable jackets clearly, Not dimmed and the ink must be suitable for cable jacket material. The size of the marking letters shall be approximately 2.5 mm.

If the initial marking fails to meet the specified requirements (i.e., improper text statement, color, legibility, or print interval), the cable may be remarked using a contrasting alternate color. The numbering sequence will differ from the previous numbering sequence, and a tag will be attached to both the outside end of the cable and to the reel to indicate the sequence of remarking.

The shipping and storage temperature range of the cable shall be -40°C to $+70^{\circ}\text{C}$. The operating temperature range of the cable shall be -40°C to $+70^{\circ}\text{C}$. The installation temperature range of the cable shall be -5°C to $+50^{\circ}\text{C}$.

4. General Cable Performance Specifications

The cable shall fulfill the following mechanical, thermal and electrical characteristics. If applicable, during and after the tests, the attenuation shall be monitored at the operating wavelength.

4.1. Tensile Performance

The cable shall be tested in accordance with IEC 60794-1-E1. The cable shall be able to withstand a permanent load (10 min) of $> 9000\text{ N}$, a short term load (1 min) of $> 13000\text{ N}$, and a breaking tensile load of $> 17000\text{ N}$. No fibers shall exhibit a measurable change in attenuation after load removal. Also, the cable shall not have evidence of jacket cracking or splitting. The maximum allowable pulling tension is 20000 N .

4.2. Crush Resistance

The cable shall withstand a compressive long term load of 5000 N for duration of 10 minutes and a short term load of 6000 N for duration of 1 minute. The load shall be applied uniformly over the length of the compression plate. The crush resistance for the aerial optic fiber cables shall be $3000\text{ N}/100\text{mm}$. The cable shall be tested in accordance with IEC 60794-1-E3. No fibers shall exhibit a measurable change in attenuation after load removal.

4.3. Cable Bend

The minimum static bending radius of the cable shall be more than 10 times the outer diameter. The minimum dynamic bending radius of the cable shall be more than 15 times the outer diameter. It shall be tested in accordance with IEC 60794-1-E11. After the test there shall be no change in fiber attenuation greater than the uncertainty of measurement.

4.4. Temperature Cycling

The cable shall be subjected to a minimum temperature of -40°C and a maximum temperature of $+70^{\circ}\text{C}$. The test shall be performed in accordance with IEC 60794-1-F1. The cable shall meet the temperature cycling test without exhibiting an average increase in fiber attenuation greater than 0.1 dB/Km for single mode fiber. This value includes the repeatability of the measurement system, which shall not be greater than ± 0.05 dB.

Water Penetration

A 1 m sample of the cable shall be subjected to a water penetration test according to IEC 60794-1-F5. After duration of 24 hours no water shall be detected at the open end of the cable core.

5. Testing

5.1. Type Test

The type tests given in Section 6 shall be performed on the fiber optic cable.

5.2. Factory Acceptance Test

The cable performance shall be proved by showing detailed test reports of the optical attenuation (if applicable) during and after the test and all relevant test parameters of the type test.

5.3. Routine Test

The optical attenuation coefficient as required in Section 3.2 shall be verified at 1550 nm on all production cable lengths. The test shall be performed according to IEC 60793-1-C1C (Backscattering technique).

6. Quality Assurance Provision

The manufacturer shall carry out quality inspection and keep a record of the test results to an extent agreed. The manufacturer shall also have a trace ability of the materials used, and of the production steps, used in the manufacturing of the cable to an extent agreed.

The supplier shall provide details of his quality control procedures that shall include the methodical recording of the results of production measurements.

Test result shall include the following:

1. Cable designation.
2. Number of fibers.
3. Fiber type.
4. Refractive index.
5. Drum no.
6. Length of cable.
7. Data of measurements.
8. Attenuation for every fiber at 1310 nm.
9. Attenuation for every fiber at 1550 nm.
10. Zero-dispersion wavelength for every fiber.
11. Zero-dispersion slope for every fiber.
12. Maximum and minimum value of mode field diameter of fibers in the cable.
13. Maximum and minimum value of cut-off wavelength in the cable.
14. A core-concentricity error of fibers in the cable.
15. Dispersion.
16. The test results shall be attached on the drum.
17. Packaging

Cables shall be uniformly wound with no gaps between successive turns.

Cable ends shall be effectively sealed against physical damage, the ingress of water and loss of jelly filling, opening and re-sealing being possible at least ten times.

Identification of the cable drum shall include the following parameters:

1. Name of manufacturer and year of production.
2. Cable designation and content.
3. Cable ID numbers.
4. Length of cable and start and finish mark.
5. Order no.
6. Any other useful information.

Drum size shall preferably be suitable for cable lengths of at least 3000 m as one piece. Longer pieces are preferable.

Tenderers shall state the maximum drummed cable length of each cable type offered and the size and gross weight of loaded drums.

The cables shall be supplied on a wooden drum. Each length of cable shall be wound on a separate drum.

The diameter of the drum barrel shall be large enough to prevent damage to the cable during reeling or unreeling. The diameter of the barrel shall not be smaller than 40 times the outer diameter of the cable.

The drum shall be durable and constructed such as to prevent damage to the cables during shipment and handlings.

Lags or other suitable means of protection shall be applied to the drum to prevent damage to the cables during shipment and storage. Nails and staples used in the construction of the drum must not be placed in a position where they can damage the cables. The drums shall be non-returnable.

Drums with a ramp should be used. For test purposes a length of approx. 4 - 5 m of the inner end shall be accessible.

The cable ends shall be sealed with shrinking caps and fastened tightly. A protective wrap shall be applied over the outer layer of the cable on each reel. The wrap shall be weather resistant and shall not be removed until the cable is installed.

Marking plates, containing following information shall be securely attached to the outer side on each drum flange:

- Type and size of cable.
- Cable length in meters.
- Gross weight in kilograms.
- Reel number.
- Manufacturer's name.
- Year of manufacture.
- Project name and number.
- Arrow showing roll direction.

The plates shall be made of an all-weather resistant non-corrosive material

8. Miscellaneous

The cable manufacturer shall introduce and maintain a quality system according to ISO 9001.

All optical fibers in each manufactured length shall be tested for attenuation according to Section 5.3. The measured attenuation coefficients (in dB/km) shall be provided with each cable reel. For lengths less than one kilometer, in consideration of test limitations, values that are within 0.05 dB of the specified end to end attenuation may be reported as the specification limit coefficient.

At the request of the Employer, the cable manufacturer shall provide installation procedures, all necessary equipment for the installation process and technical support concerning the items contained in this specification.

ANNEX F-3: TECHNICAL SPECIFICATIONS OF OPTICAL DISTRIBUTION FRAME

1. Scope

This specification covers the requirements for Optical Distribution Frames (ODF) to be used for termination of optical fiber cables in Technical Rooms where a large number of optical fibers are expected to be involved (Aggregate Points and Pops).

1.1. Definitions

For the purpose of this specification the following definitions are applicable:

Optical Distribution Frame (ODF)

The system required for the termination and/or through connection of optical fiber cables in an orderly, systematic and flexible way in order to gain simple and reliable access to the optical fibers.

Patch Cord

A specified length of tight-buffered optical fiber, with or without a strength member of aramid yarns stranded around the fiber and covered by an outer sheath, fitted with optical connectors at both ends.

Pig-tail

A specified length of tight-buffered optical fiber, with or without a strength member of aramid yarns stranded around the fiber and covered by an outer sheath, fitted with optical connectors on one end only.

2. General Principles

The ODF should be given a dedicated location within an equipment area to facilitate an orderly collection and termination of optical fiber cables. Each optical fiber is terminated with an optical connector and accessed from a patch-panel at the ODF. It shall be possible to access each incoming optical fiber at the ODF and redistribute further to their final destination by the means of optical patch cords.

Thus the ODF provides the flexibility point for all the optical cables involved, from where all fibers can be distributed, re-routed or cross-connected in a simple way, depending on the requirements and needs at any particular time.

3. Design

- 3.1. The ODF shall have a flexible and modular design, with provisions for future expansions, possibility to add new cables, or to remove existing ones. The parts and components shall be pre-assembled, as far as possible, in order to minimize the amount of work to be carried out at site when the ODF is installed.
- 3.2. The ODF shall comprise a system of racks, panels, etc. which shall be possible to order in units according to requirements, any other design arrangement may be offered. Suppliers may offer for wall mounted ODF with explanation to be provided.
- 3.3. The design of the ODF system shall take into account the handling properties of the optical indoor cable with special regard to the minimum allowed bending radius of the cable. At no place may the optical fibers be bent below a minimum allowed bending radius of 35 millimeters, and provisions shall be made in order to prevent the fibers from being squeezed anywhere in the rack.
- 3.4. It shall be reasonably simple to add new optical cables to the ODF and to install the corresponding patch-panels, etc. It shall be possible to carry out the work with a minimum of manpower using only common place tools.
- 3.5. The overall design shall be such that each optical connector is easy to access, connect or disconnect. Provisions shall be made to prevent accidental disconnection of optical connectors as well as physical damage to optical fibers due to unintentional mechanical influence (e.g. a ladder accidentally hitting the rack or patch panel).
- 3.6. Immediate access to the optical connectors shall be prevented by means of doors or panels. It shall be possible to lock or secure these to prevent unauthorized tampering with the connectors.
- 3.7. The ODF system shall include facilities for systematic and safe storage of excess lengths on optical patch cords. The minimum requirement is that it shall be possible to store at least 4 meters of excess length on each 3 mm diameter optical patch cord without causing excessive strain on the fibers.

- 3.8. The design and materials used for the ODF shall be compatible for use in a protected environment with controlled temperature and humidity and only occasional exposure to the temperature and humidity of a tropical coastal environment.
- 3.9. The ODF shall be of rack mounted type. Suppliers may offer as an option for wall mounted type.
- 3.10. The ODF shall be capable of operating over a full temperature range of (-30°C to +70°C), without any damage or significant change in performance.

4. Optical Connectors

The optical connectors to be used shall be of high-grade SC/UPC type as described below.

4.1. SC/UPC Connector Plug and Adapter

The optical fibers shall be terminated with PC-polished optical connector plugs of SC type.

SC/UPC Adapter

The patch panels of the ODF shall be furnished with adapters for optical connectors.

5. Splices

Where splicing of pigtails is required by the ODF design the following shall apply:

5.1. Facilities for Splicing

For the protection and management of the fibers the ODF shall be furnished with splice trays or fiber organizers where the fiber joint shall be secured and excess fiber from the joint is stowed away. The splice tray design shall take into account the minimum allowed bending radius of 30 mm for the fiber.

The strength member of the indoor cable shall be secured safely to the same shelf (unit, box, etc.) where the splice trays are installed. Unprotected primary coated fiber is not allowed anywhere in the rack except inside the protective cover of the splice trays. Tight buffered 0.9 mm fibers without additional protection shall also be protected and may only be used inside the patch-panels.

5.2. Method of Splicing

The optical pigtails, whether they are bare 0.9 mm tight-buffered fibers or have aramid yarn protection, shall be jointed by the means of fusion splicing, and the splices shall be protected by splice protection sleeve.

5.3. Splice Loss

The maximum allowed splice loss shall be ≤ 0.1 dB at 1310nm, and not exceed than 0.07dB at 1550nm.

Copy not for sale

ANNEX F-4: TECHNICAL SPECIFICATIONS OF MINI OPTICAL DISTRIBUTION FRAME AND ITS RELATED ACCESSORIES

1. Scope

This specification covers the requirements for Mini Optical Distribution Frames to be used for termination of optical fiber cables in Technical Rooms where a smaller number of optical fibers are expected to be involved (Connection Points).

1.2. Definitions

For the purpose of this specification the following definitions are applicable:

Mini Optical Distribution Frame

The system required for the termination and/or through connection of optical fiber cables in an orderly, systematic and flexible way in order to gain simple and reliable access to the optical fibers.

Patch Cord

A specified length of tight-buffered optical fiber, with or without a strength member of aramid yarns stranded around the fiber and covered by an outer sheath, fitted with optical connectors at both ends.

Pig-tail

A specified length of tight-buffered optical fiber, with or without a strength member of aramid yarns stranded around the fiber and covered by an outer sheath, fitted with optical connectors on one end only.

2. General Principles

The Mini ODF should be given a dedicated location within an equipment area to facilitate an orderly collection and termination of optical fiber cables. The Mini ODF shall be placed into standard rack mount, and shall be suitable for most connectors and cable types. This unit contains space for pigtails, shelves, and patch panel.

Thus the Mini ODF provides the flexibility point for all the optical cables involved, from where all fibers can be distributed, re-routed or cross-connected in a simple way, depending on the requirements and needs at any particular time.

3. Design

Mini ODF is used for applications in shared or growing networks. It is designed for splicing and cross-connecting fibers. The splicing function is handled by one or two cassettes, accommodating fusion splices protected by heat shrink sleeves. Connection and cross-connection are done by using any standard connector. The Sliding Patch & Splice Panel provides easy access to connections from the front of the frame, and accommodates left or right patch cord exit. The Mini ODF is ideal for use where networks may change more frequently or become complex.

- 3.1. The design of the Mini ODF system shall take into account the handling properties of the optical indoor cable with special regard to the minimum allowed bending radius of the cable. At no place may the optical fibers be bent below a minimum allowed bending radius of 35 millimeters, and provisions shall be made in order to prevent the fibers from being squeezed anywhere in the rack.
- 3.2. The overall design shall be such that each optical connector is easy to access, connect or disconnect. Provisions shall be made to prevent accidental disconnection of optical connectors as well as physical damage to optical fibers due to unintentional mechanical influence (e.g. a ladder accidentally hitting the rack or patch panel).
- 3.3. Immediate access to the optical connectors shall be prevented by means of doors or panels. It shall be possible to lock or secure these to prevent unauthorized tampering with the connectors.
- 3.4. The design and materials used for the ODF shall be compatible for use in a protected environment with controlled temperature and humidity and only occasional exposure to the temperature and humidity of a tropical coastal environment.
- 3.5. The Mini ODF shall be capable of operating over a full temperature range of (-30°C to +70°C), without any damage or significant change in performance.

4. Optical Connectors

The optical connectors to be used shall be of high-grade SC/UPC type as described below.

4.1. SC/UPC Connector Plug and Adapter

The optical fibers shall be terminated with PC-polished optical connector plugs of SC type.

4.2. SC/UPC Adapter

The patch panels of the Mini ODF shall be furnished with adapters for optical connectors.

5. Splices

Where splicing of pigtails is required by the Mini ODF design the following shall apply:

5.1. Facilities for Splicing

For the protection and management of the fibers the Mini ODF shall be furnished with splice trays or fiber organizers where the fiber joint shall be secured and excess fiber from the joint is stowed away. The splice tray design shall take into account the minimum allowed bending radius of 30 mm for the fiber.

The strength member of the indoor cable shall be secured safely to the same shelf (unit, box, etc.) where the splice trays are installed. Unprotected primary coated fiber is not allowed anywhere in the rack except inside the protective cover of the splice trays. Tight buffered 0.9 mm fibers without additional protection shall also be protected and may only be used inside the patch-panels.

5.2. Method of Splicing

The optical pigtails, whether they are bare 0.9 mm tight-buffered fibers or have aramid yarn protection, shall be jointed by the means of fusion splicing, and the splices shall be protected by splice protection sleeve.

5.3. Splice Loss

The maximum allowed splice loss shall be ≤ 0.1 dB at 1310nm, and not exceed than 0.07dB at 1550nm.

ANNEX F-5: TECHNICAL SPECIFICATIONS OF OPTICAL CONNECTORS AND ADAPTERS

1. Scope

This document specifies the requirement of optical connector sets of SC/UPC-type to be used in single-mode optical fiber telecommunication systems.

A connector set is: "The complete set of connector components required to provide demountable coupling between optical fibers". The length of fiber or cable on each side of the connector set shall be 3 meters (minimum).

2. Design

2.1. General

The ferrule of the optical connector shall be made of zirconia stabilized ceramic.

When the connector is mounted on a cable (or a tight buffered fiber) the fiber shall be fixed with epoxy in the cavity of the ferrule. Then the end face of the ferrule with the fiber shall be polished. In order to ensure physical contact the shape of the ferrule shall be spherical.

The cable (jacket and strength members) shall be fixed to the connector by means of a crimp sleeve.

Mating with another connector shall be accomplished by the means of an adapter with a split sleeve.

2.2. Material

The supplier shall give details of the materials used in different parts of the proposed connector.

The connector housing shall be of an all-metal design.

2.3. Ferrule

The ferrule end face shall be UPC-polished and meet the following requirements:

Ferrule end face curvature (r)	$10 < r < 25 \text{ mm}$
Vertex offset of ferrule tip (convex vertex eccentricity from ferrule center)	$< 50 \text{ }\mu\text{m}$
Fiber undercut from ferrule end face:	$\leq 0.05 \text{ }\mu\text{m}$
Fiber protrusion from ferrule end face:	$\leq 0.10 \text{ }\mu\text{m}$
Outside diameter (A)	$2.4990 \pm 0.0005 \text{ mm}$
Tolerance of cavity diameter	$+1, -0 \text{ }\mu\text{m}$
Concentricity error C.E. of cavity	$< 1.4 \text{ }\mu\text{m}$
Angular misalignment Θ	$< 0.2^\circ$

3. Performance Requirements

3.1. Visual Inspection

3.1.1. Overall Inspection of Connectors

Each connector shall be properly packed. The package shall be marked with, the name of the manufacturer and the manufacturing date.

The connector itself shall be legibly and durably marked with the identity mark of the manufacturer and the manufacturing date code.

3.1.2. Inspection of the End Face

The end face shall be clean and free from residues of glue. Using a microscope with a maximum magnification of 200x no scratches or break out of glass pieces shall be seen.

3.2. Insertion Loss

Requirements:

	Mean	Maximum
Allowable attenuation:	$\leq 0.25 \text{ dB}$	$\leq 0.50 \text{ dB}$

3.3. Return Loss

Requirements:

Allowable return loss:	≥ 40 dB
------------------------	--------------

4. Temperature

The connector shall be capable of operating over a full temperature range of (-30°C to +70°C), without any damage or significant change in optical performance.

Copy not for sale

ANNEX F-6: TECHNICAL SPECIFICATIONS OF OPTICAL CABLE SPLICE ENCLOSURES

1. Scope

This specification covers the requirements of splice enclosures to be used for splicing of all types of optical cables. Thus it is applicable for both duct and aerial cables.

2. General

The design of the splice closure shall consider ITU-T recommendation L.13 “Sheath joints and organizers of optical fiber cables in the outside plant” and the requirements of this specification.

It shall be possible to use the splice closure installed in manholes, in handholes, on poles, in cable vault, etc. It is the intention to use the splice closure to be installed in chambers or on poles.

The closure shall be re-enterable, i.e. possible to open and close several times, without wear or impairment of its water tightness and/or other essential features.

The closure shall be equipped with fiber cassettes and organizers that are easy to use and which provide full protection to the fibers.

3. Handling Aspects

3.1. The splice closure shall have a robust and reliable design and well adapted to the conditions in the field. It has to work even if minor un-intentional deviations at the installation procedure are made.

3.2. The splice closure shall have as few parts as possible.

3.3. Tools that require calibration should not be required for work with the closure.

3.4. The use of melt resin or glue shall be avoided if possible.

3.5. Work with the closure shall be possible in a cramped room, e.g. manholes.

3.6. Work with the closure shall be possible without bending the fibers below their minimum allowed bending radius at any stage of work.

- 3.7. Work with the closure shall not require extensive training.
- 3.8. Work with the closure shall be possible to be carried out by one man alone.
- 3.9. Work with the closure shall not involve any risk of injury to the working personnel.
- 3.10. The method of work shall be described in an easy to understand installation instruction or manual enclosed with each closure in English and Modern Standard Arabic.
- 3.11. All the parts of the splice closure, except for the materials required for jointing of the fibers, shall be packed in one package, with a clear marking of its contents if required. If the storage time is limited that shall be stated on the package.

4. Design

The contractor shall furnish and install fiber optic splice closures in locations where splices require protection as shown on the plans and as ordered by the Engineer. The fiber optic splice closure shall meet all requirements stated in the following specification:

- 4.1. The splice closure shall provide a good mechanical protection.
- 4.2. The splice closure shall incorporate a mechanical compression and/or mastic tape sealing system to maintain a barrier against water and moisture penetration.
- 4.3. The splice closure shall be reasonably resistant against unauthorized tampering, vibration and wear, as well as against biotic attack (rodents, termites, etc.).
- 4.4. The splice closure shall be resistant against corrosion.
- 4.5. The splice closure shall be resistant against UV-radiation.
- 4.6. The splice closure shall be made of materials, which are mutually compatible.
- 4.7. The size of the splice closure shall be in proportion to the number of cables, fibers in each cable and to the number of splices.
- 4.8. It shall be easy to re-enter the splice closure and close it again several times. Also the closure shall be capable of accepting additional cables without removal of the sheath retention or strength member clamping hardware on previously installed cables or disturbing existing splices.
- 4.9. The design of the closure must be such that the fibers are never bended below their minimum allowed bending radius of 35 mm during any phase of the splicing work.

- 4.10. A splice closure, which shall be used for a branching joint, shall be possible to assemble without the necessity to cut all the fibers.
- 4.11. The fiber optic closure shall be available in distinct sizes to accommodate a variety of cable entries. A fiber optic closure shall be capable of accommodating up to four cables in a butt or branch configuration.
- 4.12. It shall be possible to split and branch groups of 6 fibers from the splice closure.
- 4.13. Inside the splice closure there shall be space enough for an excess length of fiber of at least 2 meters. This length is based on expected future needs for maintenance or redistribution of fibers.
- 4.14. The splice closure shall contain, or have the space for, fiber organizers for storage of fiber joints as well as the excess lengths on fibers.
- 4.15. The fiber organizers shall provide good protection to the fibers and their joints, and have space for identification of each fiber.
- 4.16. The splice closure together with the fiber organizer shall facilitate easy access to any optional fiber within the closure for work without affecting the service on the other fibers.
- 4.17. In the splice closure it shall be possible to terminate any possible metallic conductor in the optical cable in such a way that they are easily accessible and possible to equip with over voltage protection devices.
- 4.18. The splice closure shall be possible to use on cables with basically a circular cross-section and shall be adapted to the dimensions of the cables to be connected.
- 4.19. The splice closure shall provide satisfactory anchorage of the jackets, armoring and strength members of the cables.
- 4.20. The splice closure shall allow metallic parts of the cables, if any, to be bridged over so that a satisfactory electrical connection between them is achieved. It shall be possible to ground metal parts of the cable, and it shall also be possible to separate all the metal parts.
- 4.21. For manhole installation it shall be possible to attach the splice closure to a manhole wall by the means of attachment devices, as shown in the figure below, all necessary materials for fixing shall be included in the offer.

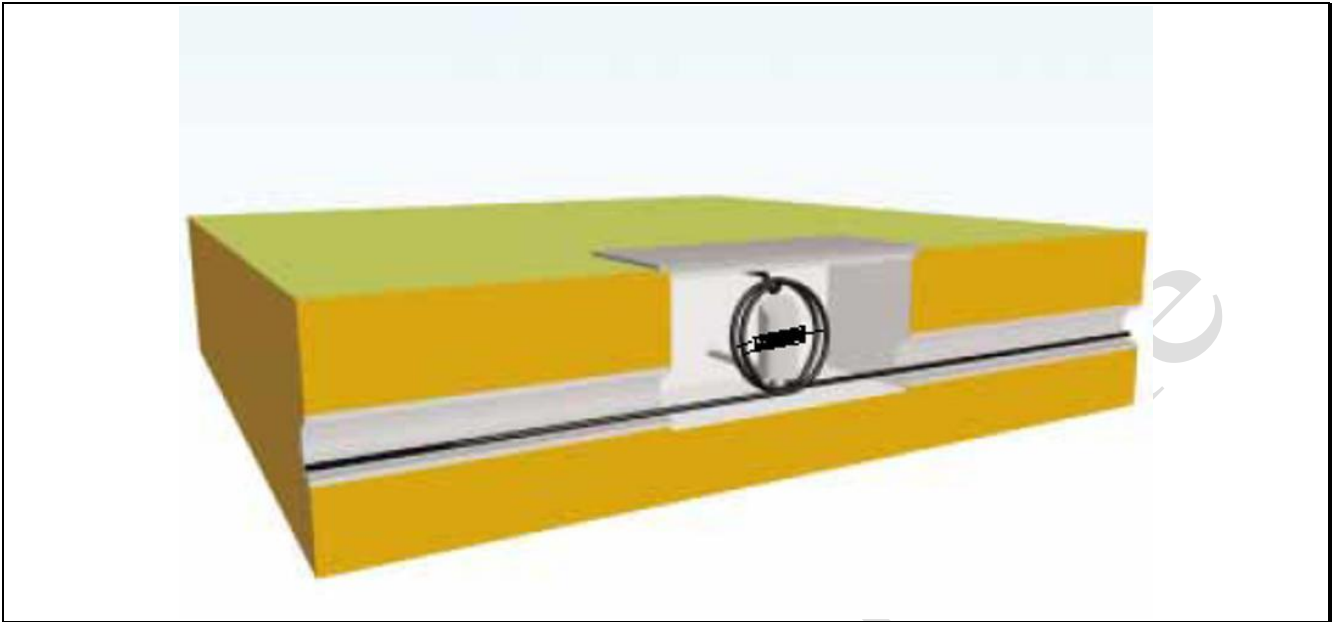

Splice Closures for Duct Cable

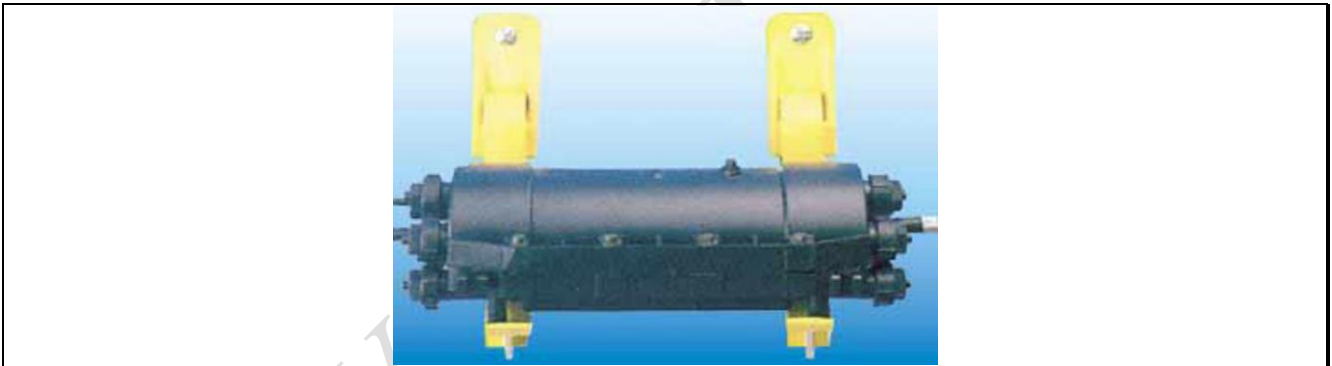

Example of a Splice Closures for Duct Cable

- 4.22. For pole installation it shall be possible to attach the splice closure to the pole by the means of attachment devices, as shown in the figure below, all necessary materials for fixing shall be included in the offer.

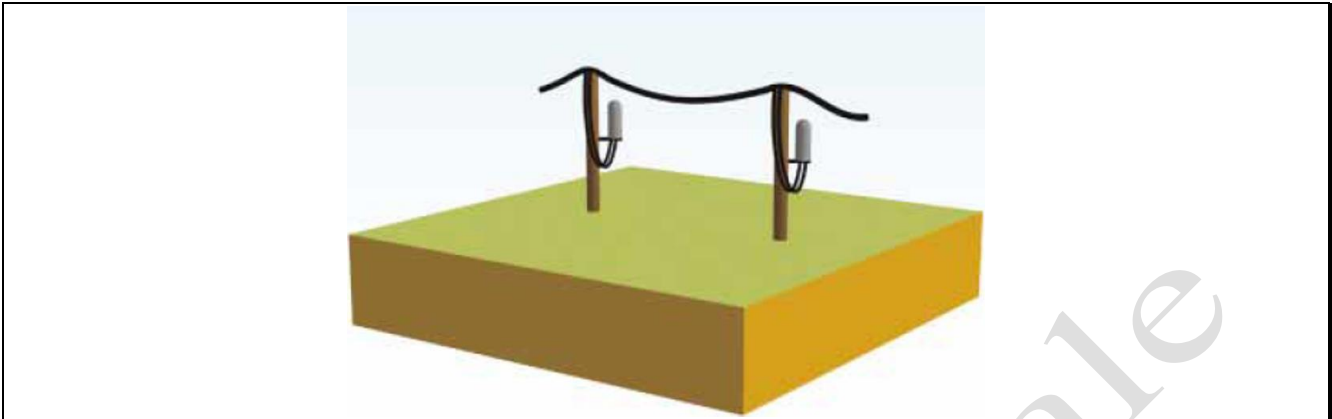

Splice Closures for Aerial Cable



Example of a Splice Closures for Aerial Cable

- 4.23. It shall be easy to furnish the splice closure with an external marking.
- 4.24. The splice closure shall be capable of operating over a full temperature range of (-30°C to +70°C), without any damage or significant change in performance.

ANNEX F-7: TECHNICAL SPECIFICATIONS FOR DUCT CABLE HARDWARE AND SUPPORT ACCESSORIES

1. Cable U-Guard shall be used to protect the cable at the points of potential abrasion.

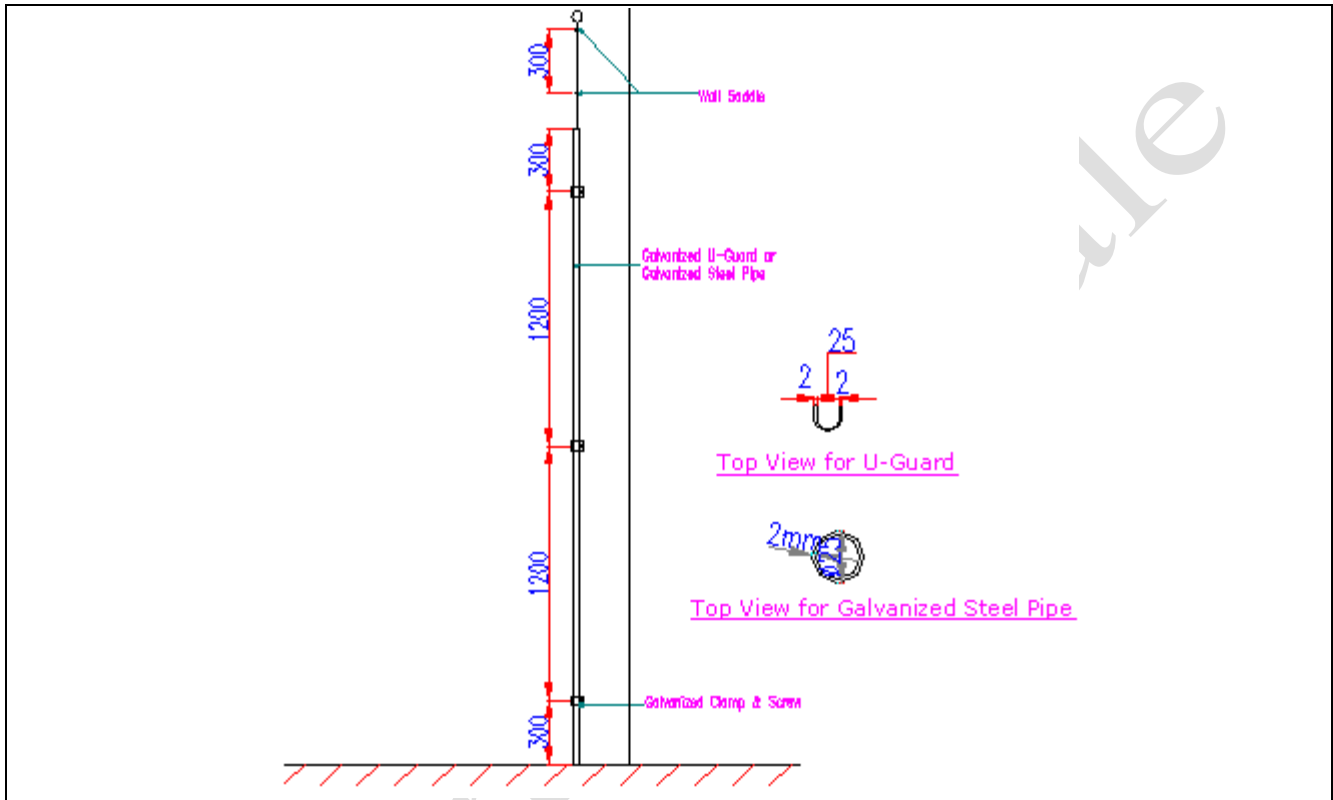

U-Guard or Galvanized Steel Protector Pipe

2. Cable trays with cover shall be used to protect cables installed on wall.
3. Cable Tray/U-Guard installations shall be carried out with no damage to the wall surface.

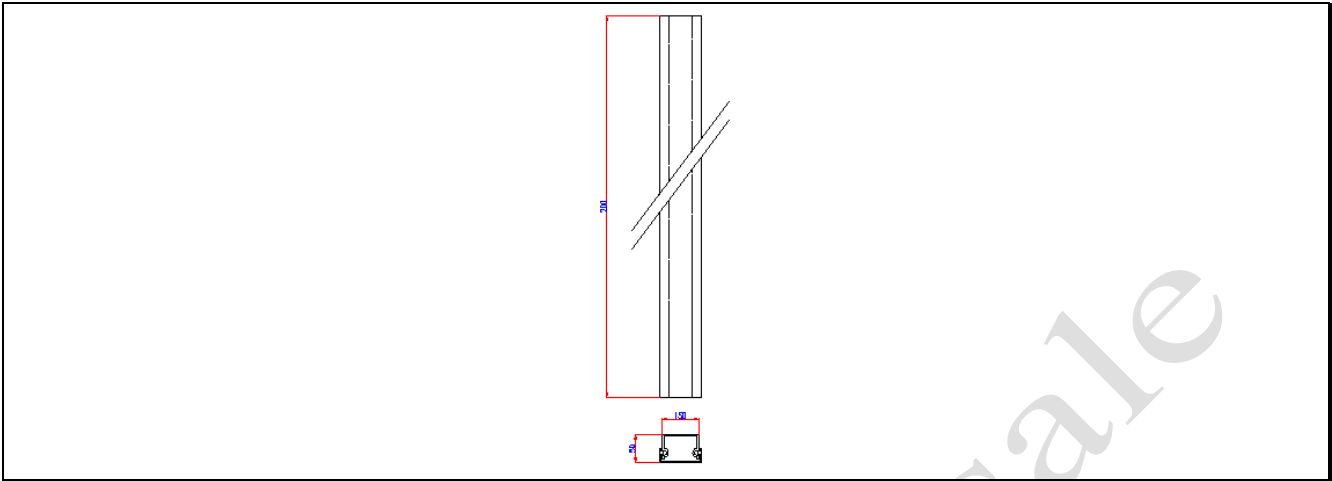

Side & Top View for Galvanized Steel Cable Tray with Cover

4. Corrugated rigged tube ($\text{Ø } 22 \text{ mm}$) shall be used to protect fiber optic cables in manholes, handholes, pull boxes, and at building entrances.



Corrugated Rigged Tube ($\text{Ø } 22 \text{ mm}$) & Accessories

5. Wall mounted bracket for splice box to be installed inside Manholes or Hand holes, the bracket should be fitted to the splice box supplied by the contractor.

ANNEX F-8: TECHNICAL SPECIFICATIONS FOR AERIAL CABLE HARDWARE AND SUPPORT ACCESSORIES

1. Cable Storage

All slack cable storage locations require the installation of slack cable storage brackets. The fiber cable storage bracket insures a proper bending radius for the stored fiber optic cable and provides for horizontal storage and tie ring for storage of multiple cables and loops. The figures below illustrate possible slack cable storage configurations.

There are two general types of aerial cable support hardware: Figure_8 -Aerial Cable Storage and Cross - Aerial Cable Storage. these types differ each other and the supervision engineer decide which type should be used..

1.1 Figure_8 - Aerial Cable Storage

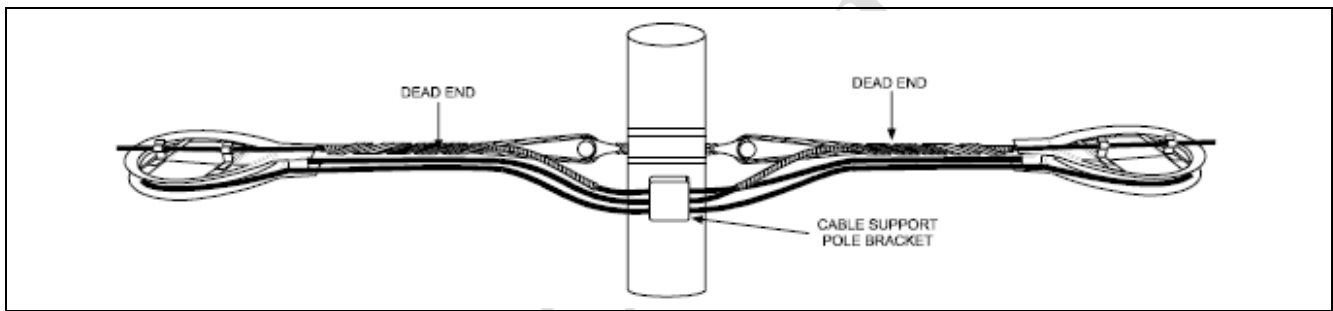

Figure_8 - Aerial Cable Storage Configuration for Pass-Through Cables

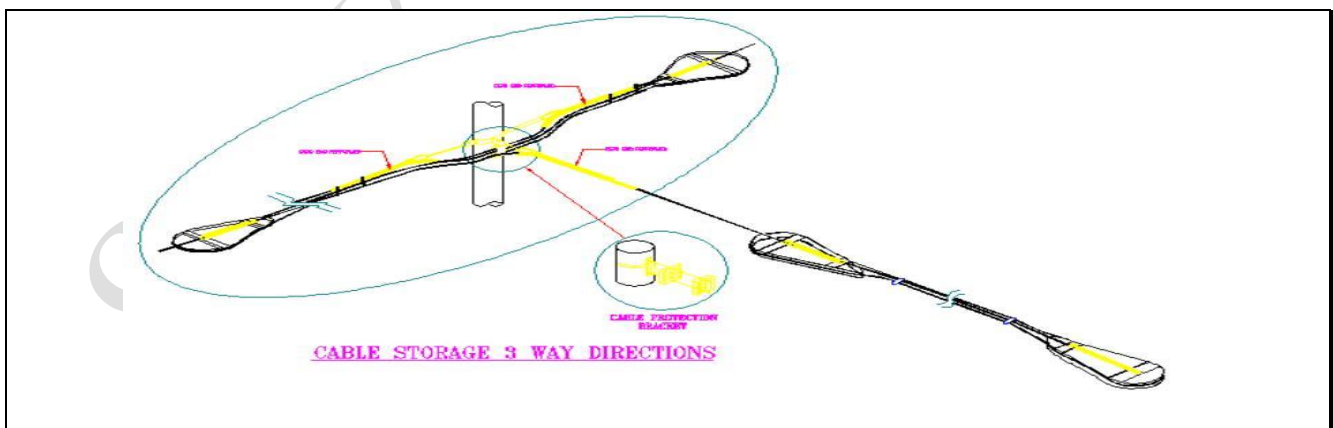

Figure_8 - Aerial Cable Storage Configuration for Angled Cables

1.2 Cross - Aerial Cable Storage



Cross - Aerial Cable Storage Configuration With Cross-bar



Cross - Aerial Cable Storage Configuration for Angled Cables

2. Aerial Cable Support Hardware

There are two general types of aerial cable support hardware: Dead-end and tangent (pass-through) assemblies.

2.1. Dead-end Grip

Dead-end bracket is used at the point of cable termination. The figure below shows an aerial cable dead-end Grip.

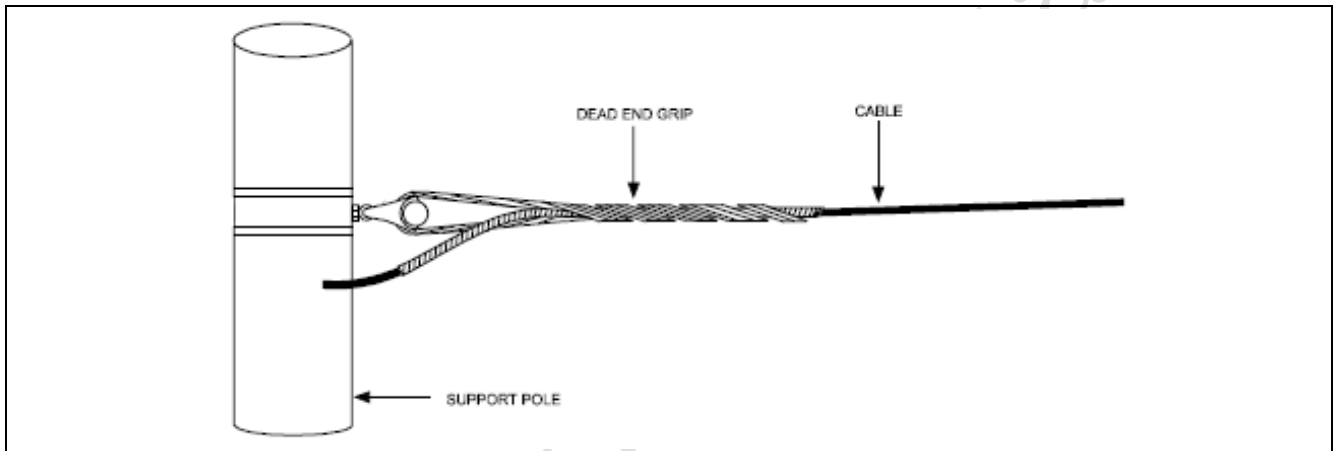

Aerial Cable Dead-end Grip

2.2. Pass-Through Bracket

Pass-through bracket is normally installed after the span has been tensioned. The figure below illustrates a front view of a pass-through bracket. To install the cable, the hinged top is opened and the bottom pad is inserted. Then the cable is placed on the pad, the top pad is placed over the cable, the top is closed, and the bolt is tightened to hold the cable in place.

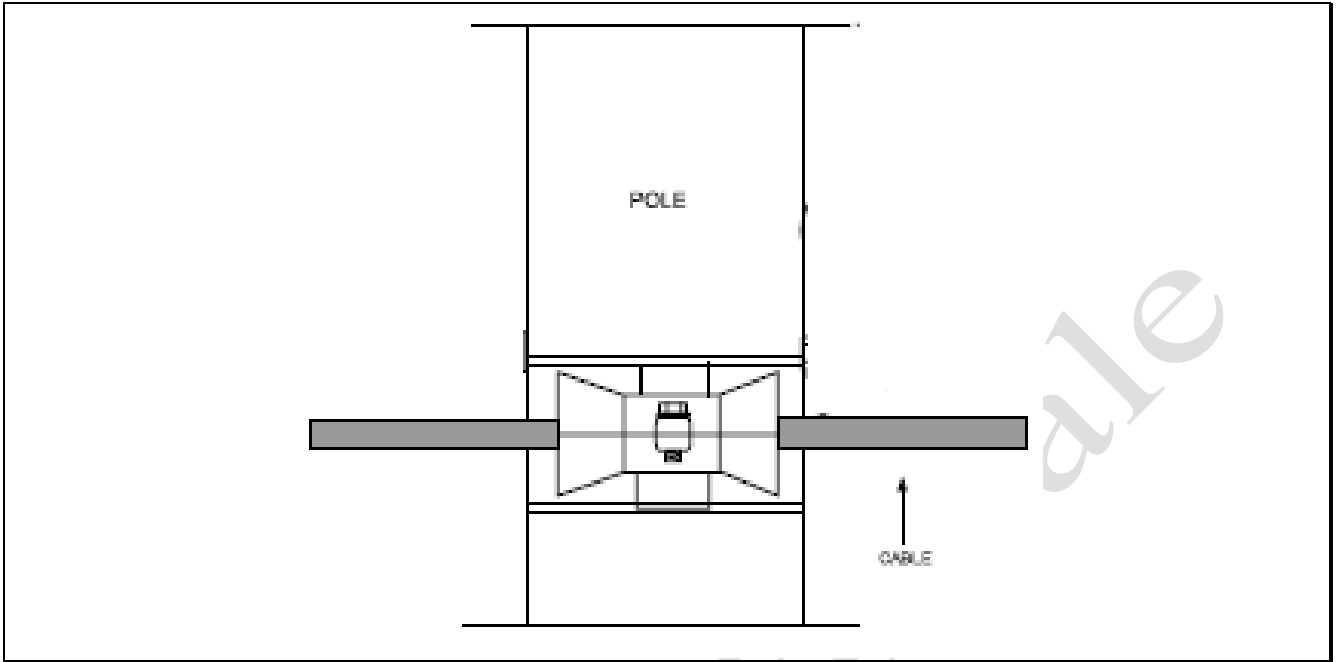

Pass-Through Bracket

copy not for sale

3. Cable Mounts

Cable mounts is normally used to hold the aerial cable on the pole (wooden, steel, concrete).

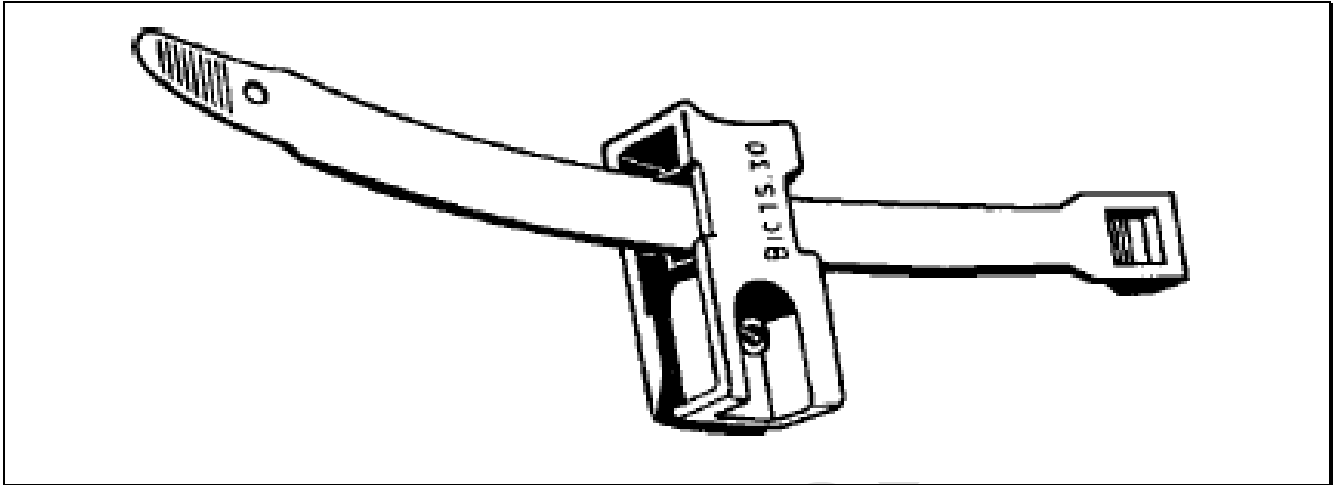

Aerial Cable Mount (for Steel, Concrete, and Wooden Poles)

4. Splice Closures Clamp

Strapped clamp is normally used to hold the closures on poles (wooden, steel, concrete) as shown in figure below.

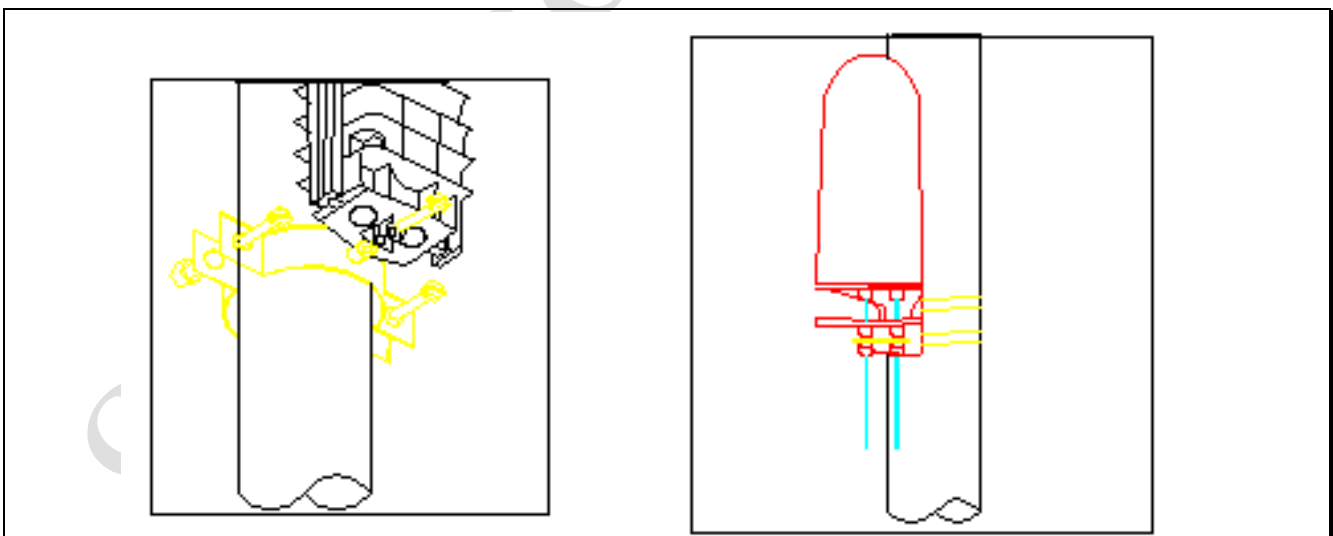

Splice closures clamp strapped with metal bends

5. Galvanized Pipe Holder

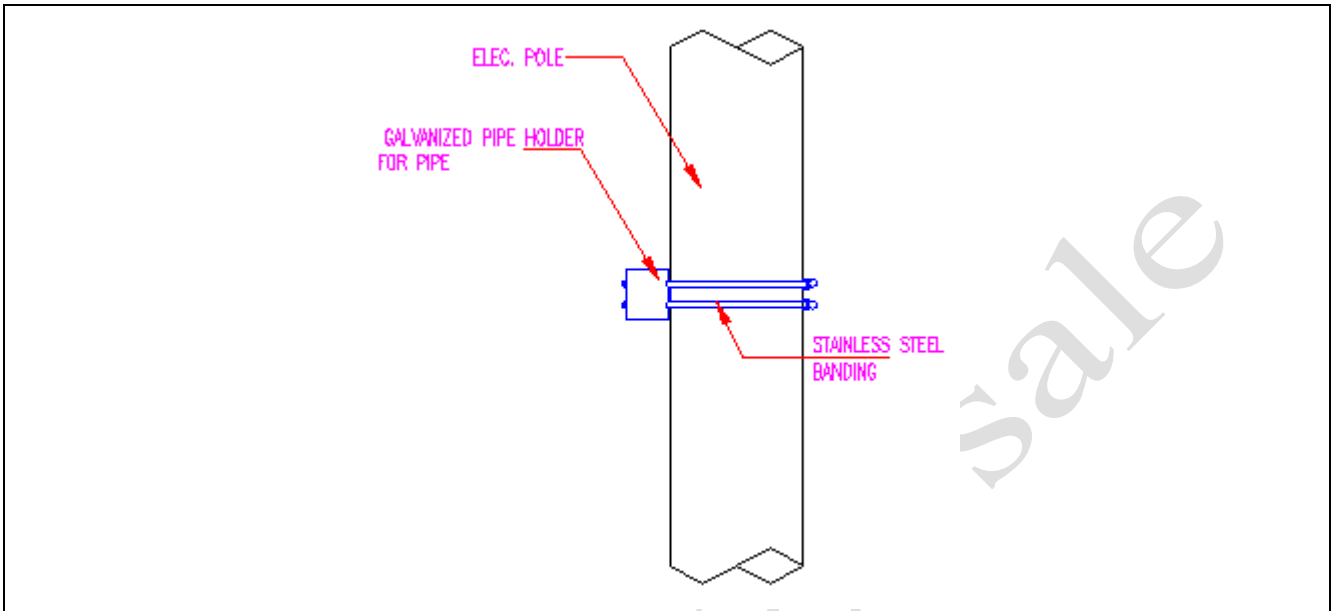

Galvanized Pipe (Ø 25, 50 mm) Holder

ANNEX G: AERIAL CABLE SAG AND CLEARANCE:

Aerial Cable Sag and Clearance

Planning for aerial cable installation includes taking into account proper clearances, cable types and properties, the mechanical stress loading on the cable, and span length.

Medium Voltage Network

Planning for proper clearances requires knowing the “sag” of the proposed installation. The Contractor shall plan aerial cable installation to allow for a minimum clearance of five (5) meters above ground level and three (3) meters from existing medium voltage power cables at the electricity poles, which may be reduced to 2m to guarantee the 5m clearance above the ground. The minimum clearance (Worst Case) of the mid-point of the fiber optic cable (max. sag location) should not be less than one (1) meter from the mid-point of electrical cable (max. sag location).

Low Voltage Network

Clearance distance of the fixing point of fiber optical cable on the pole to IDECO Network (electrical conductors) has been set at one (1) meter.

Installation conditions

In some special cases where the clearance between the fiber optical cables and the ground level is less than five (5) meters conjunctively, the distance of the fixing point of fiber optical cable on the pole to IDECO Network (electrical conductors) is two (2) meters, then poles must be erected at the mid spans or otherwise as required (If technically possible and Landowners, Municipalities, Public works agree for the route) , the newly installed poles shall be erected at an offset of one (1) meter of the alignment of the existing IDECO poles (If the route is available and Landowners, Municipalities, Public works etc...agree for this solution). The new poles will be erected at locations where transformer substations are installed at 33 KV and 11 KV line poles and are envisaged to obstruct the installation of the fiber optic cable within these locations.

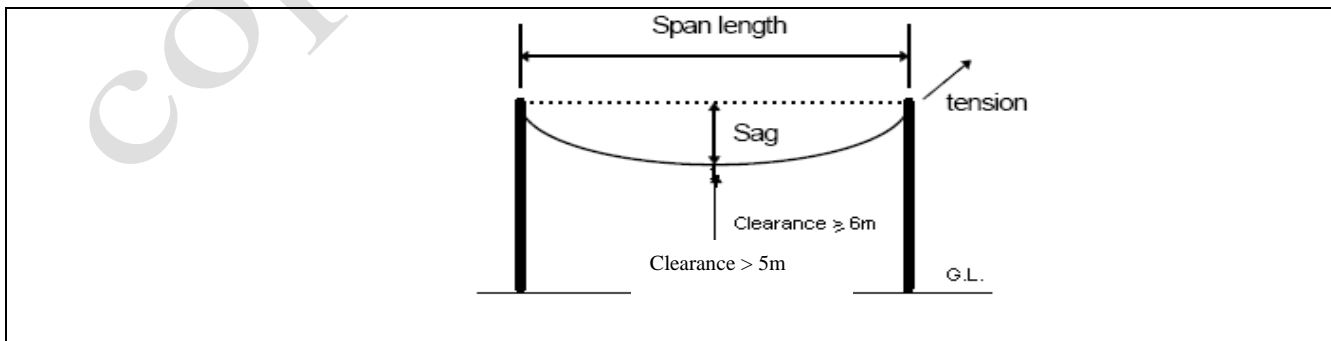

Aerial Cable Sag and Clearance

Annex H: Test and Acceptance Specifications

1. General Requirements

Tools and test instruments required for the acceptance shall be provided by the Contractor and all costs for buying these tools and test performance are to be included in the Contractor's unit rates and shall be fully described and identified by:

- Manufacturer.
- Type.
- Option(s) installed.
- Serial number.
- Last date of calibration.

The test instruments shall be adequate in both performance and quantity for the required acceptance testing. The offered test instruments shall conform to the O-Series of ITU-T Recommendations. All test instruments should have a valid calibration label stating calibration institution and expiration date.

A copy of the instruction manual shall be provided with each test instrument during the acceptance testing. The manuals shall contain all the relevant information for each type of the test instruments offered, including operation, fault diagnosis and correction, recalibration test, standards and recalibration instruments required.

The test instruments shall include all necessary power cords, patch cords, attenuators, test probes and accessories to carry out all the tests. All accessories required for performing the acceptance test should have been included in the calibration procedure.

2. Tests of Cable and Measurements of Optical Signal Attenuation

2.1. General

All adjustments to the costs for the installation of the outside plant fiber optic cables will be performed from physical segment lengths, explicitly excluding losses due to cable installation and or other manipulation. This shall make it possible to validate installed segment lengths against optical lengths from the test equipment.

2.2. Acceptance Tests

The optical fiber acceptance tests are comprised of measurements of signal strength through signal reflection (Optical Time Domain Reflectometer, OTDR) and signal insertion and detection. The Contractor shall perform all acceptance tests and compile them on the required forms. The Contractor shall submit to the Engineer all forms necessary to detail the performance of each fiber. The Contractor shall invite the Engineer to witness the final tests.

Laser Source Verification Procedure with Simple Signal Insertion and Detection Tester

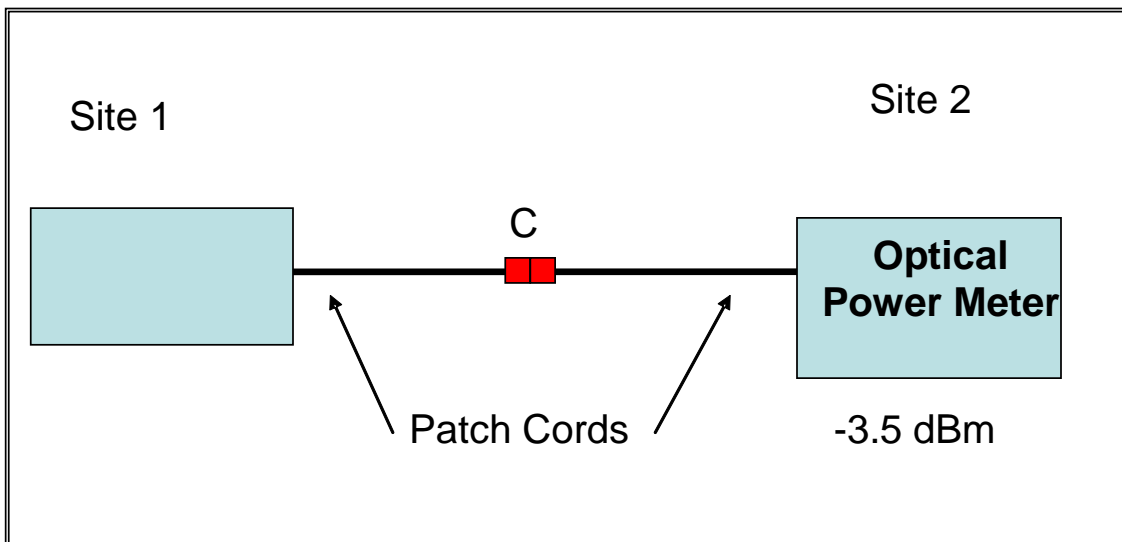

NOTE: No two lasers have the same output value. It is necessary to precisely measure this output value in order to determine the signal loss caused by the patch cords and the connectors. In knowing the precise output value, it is then possible to subtract it from the final read out. The readings must be performed on both the transmit (Tx) and receive (Rx) fiber strands, and in both directions by inverting the source and the sensor. This calibration test must be performed prior to any measurement being taken.

EXAMPLE:

A = Reference signal of the source

B = Reference signal of the sensor

C = Adaptor

Step 1 = First reading composed of: $A + C + B = -3.5 \text{ dBm}$

Step 2 = Inversion of source and sensor

Step 3 = Second reading composed of: $B + C + A = -2.8 \text{ dBm}$

Step 4 = $(-3.5) + (-2.8) = -6.3 \text{ dBm}$ divided by 2 = -3.15 dBm

Therefore, we have a reference loss of: -3.15 dBm (example value)

Example of Measurement on a Section (B)

The reading from Site 1 to Site 2 = **-18.7 dBm**

$-18.7 - (-3.15)$ (see previous section) = **-15.55 dBm**

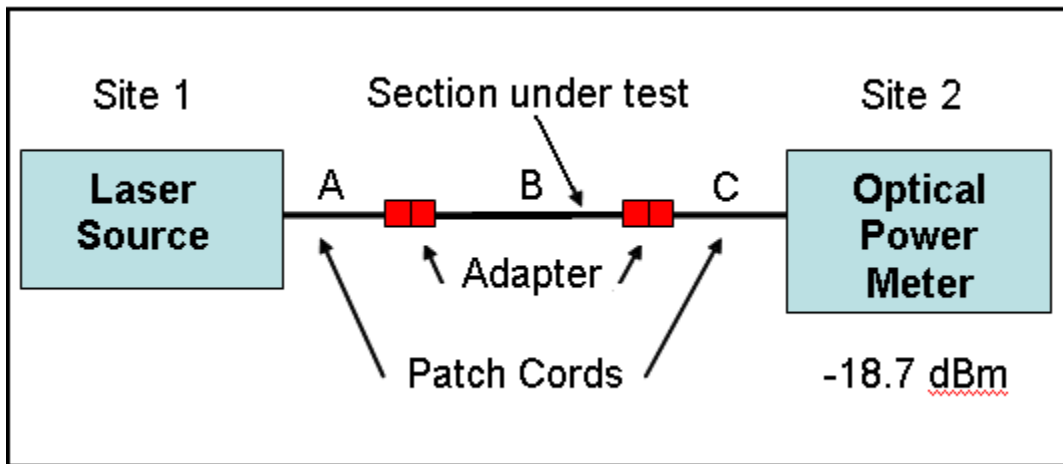

The reading from Site 2 to Site 1 = **-19.5 dBm**

$-19.5 - (-3.15)$ = **-16.35 dBm**

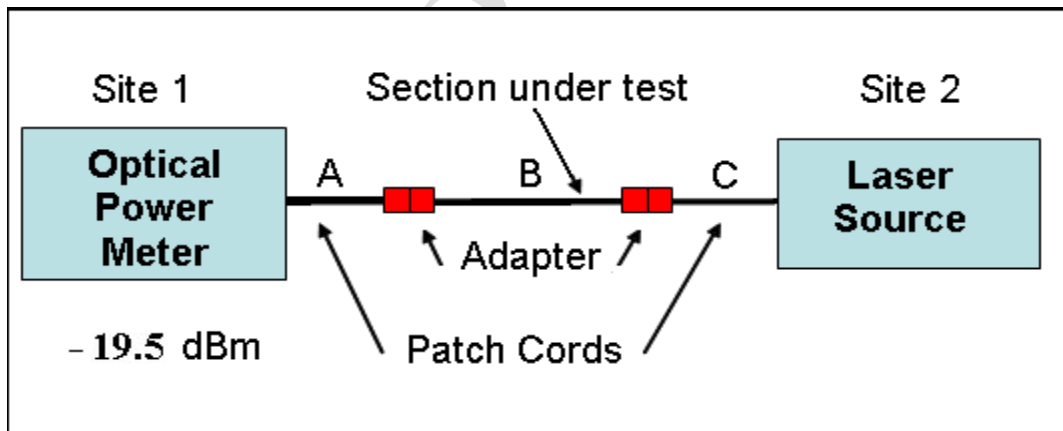

NOTE: Each reading must be performed in both directions. The result is divided by two (2) to obtain the real value.

$\frac{(-15.5) + (-16.35)}{2} = -15.93$ dBm

Therefore, the real loss on this section (B) is **-15.93 dBm** (example value)

Examples of Signal Attenuation Readings Records (loss in dB)

These readings shown in the table below have been taken only in one direction and should be repeated in the other direction.

OUTPUT SOURCE POWER: (example)				
At 1310nm = -1dbm At 1550nm = -3dbm				
A to B	Measure at 1310	Measure at 1550	Real loss at 1310	Real loss at 1550
F # 1	-15.7	-11.8	-14.7	-8.8
F # 2	-15.7	-12.09	-14.7	-9.09
F # 3	-15.99	-11.48	-14.99	-8.48
F # 4	-15.62	-11.96	-14.62	-8.96
F # 5	-15.82	-11.8	-14.82	-8.8
F # 6	-15.81	-11.72	-14.81	-8.72
F # 7	-15.85	-12.16	-14.85	-9.16
F # 8	-15.71	-12.06	-14.71	-9.06
F # 9	-15.71	-12.06	-14.71	-9.06
F # 10	-15.71	-12.06	-14.71	-9.06
F # 11	-15.71	-12.06	-14.71	-9.06
F # 12	-15.71	-12.06	-14.71	-9.06
F # 13	-15.71	-12.06	-14.71	-9.06
F # 14	-15.71	-12.06	-14.71	-9.06
F # 15	-15.71	-12.06	-14.71	-9.06
F # 16	-15.71	-12.06	-14.71	-9.06

All measurements must be saved on paper and in electronic copy in Microsoft Excel format. The real loss data should be entered in the attached acceptance sheet (MS Excel spreadsheet). The acceptance criteria for cable loss measurement are detailed on this sheet.

3. Readings with Optical Time Domain Reflectometer (OTDR)

When measuring attenuation, it is necessary to consider splices, which increase the signal (positive splices), and splices, which decrease the signal (negative splices).

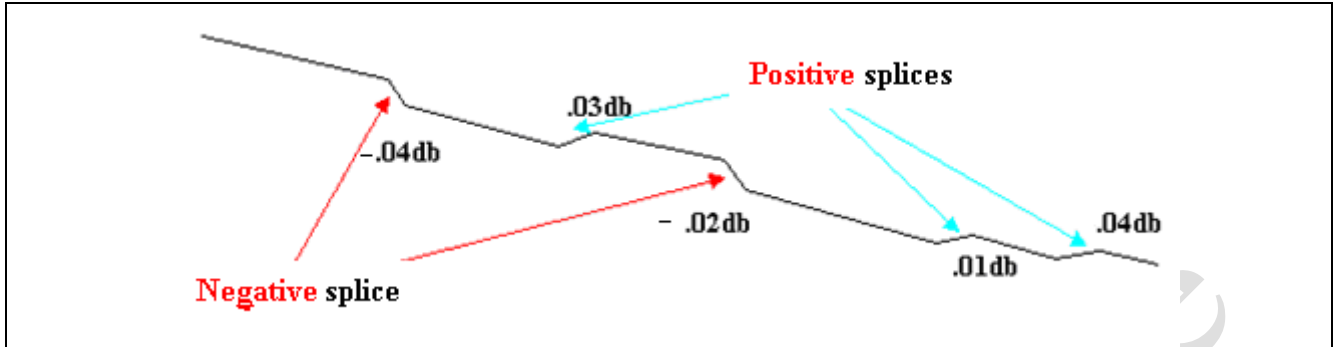

Ex: (0.08db) positive and (-0.06db) negative

In order to obtain the net loss value of a splice, it is necessary to measure the signal in both directions, add the two (2) values and divide by two (2).

In the aforementioned example, the final result would be: (0.08) + (-0.06) = 0.02 dB divided by two = 0.01 dB

Maximum Attenuation of a Fusion

The maximum attenuation for a fusion shall be of **0.1 dB** at a **1310** nanometer wavelength and of **0.07 dB** at a **1550** nanometer wavelength.

The total attenuation for a kilometer of network (dB/km) shall correlate with the specifications of the fiber optic cable manufacturer.

The true optical distance (including all slack in the cable) must be specified for each measurement; in all attenuation test reports (see Excel spreadsheet).

Paper print out of the OTDR measurements showing the complete distance and electronic files (taken from both directions on the fiber section) should be included in the acceptance report. The electronic files should be supplied with the software to run on a standard PC to open and read and display the files.

4. Additional Optical and Dispersion Measurements

Dispersion measurements shall be made within the dynamic range of the test equipment.

- a. Each fiber in each cable delivery length shall have a zero-dispersion over the range 1300-1324 nm (< 3.5 ps/nm.km). Maximum dispersion at the wavelength 1550 nm shall not exceed 18 ps/nm.km or as pair ITU-T recommendation G.655.
- b. Polarization Mode Dispersion should also be verified to guarantee future extreme high bit-rate operation (> 10 Gb/s). The PMD should have be less than 0.1 ps/sqrt(km) at 1550 nm.

In case the tests can't be executed due to test equipment not being available in country, the Factory Acceptance Test sheets of the cable installed should be provided.

5. Fiber Acceptance Report

The fiber acceptance report shall be handed over on 3 paper copies and 3 electronic copies on CD-ROM and prepared for each optical fiber cable section between the optical termination points. The acceptance report shall contain the following items.

5.1. Acceptance Report Components

General Test Identification

- Optical fiber cable section identifier.
- Start termination point identifier.
- End termination point identifier.
- Date of measurement performed.
- Name of test operator (in English) for start termination point.
- Name of test operator (in English) for end termination point.

Laser Source Specification for Start Optical Termination Point

- Manufacturer.
- Type.
- Option(s) installed.
- Serial number.
- Last date of calibration.

Laser Source Specification for End Optical Termination Point

- Manufacturer.
- Type.
- Option(s) installed.
- Serial number.
- Last date of calibration.

Power Meter Specification for Start Optical Termination Point

- Manufacturer.
- Type.
- Option(s) installed.
- Serial number.
- Last date of calibration.

Power Meter Specification for End Optical Termination Point

- Manufacturer.
- Type.
- Option(s) installed.
- Serial number.
- Last date of calibration.

OTDR Measurement Specifications for Start Optical Termination Point

- Manufacturer.
- Type.
- Option(s) installed.
- Serial number.
- Last date of calibration.

OTDR Measurement Specifications for End Optical Termination Point

- Manufacturer.
- Type.
- Option(s) installed.
- Serial number.
- Last date of calibration.

Dispersion and PMD Measurement Specifications (if not supplied with factory drum test sheet)

- Manufacturer.
- Type.
- Option(s) installed.
- Serial number.
- Last date of calibration.

5.2. The results of the attenuation and OTDR measurements shall be gathered on the fiber section acceptance form as shown below. This acceptance sheet shall be given as a paper copy and as an electronic copy (Microsoft Excel 2003) on the CD-ROM.

5.3. The print-out of the OTDR measurements in both directions for both 1310 nm and 1550 nm shall be included in the fiber acceptance report and an electronic copy of the measurement files on the CD-ROM including a full copy of the viewer of these measurement files (HP, Siemens, Anritsu or other).

Example Sheet

Section Start optical termination point (A) To End optical termination point (B)

cable section ID	
Start point ID	

End point ID	
---------------------	--

Fibre No.	1550 nm				1310 nm			
	A to B (dB)	B to A (dB)	Difference Loss (dB)	Average (dB)	A to B (dB)	B to A (dB)	Difference Loss (dB)	Average (dB)
1	-5.21	-4.94	0.27	-5.08	-7.36	-7.95	0.59	-7.66
2	-4.98	-4.79	0.19	-4.89	-7.12	-7.71	0.59	-7.42
3	-5.64	-5.28	0.36	-5.46	-7.77	-8.32	0.55	-8.05
4	-4.76	-4.63	0.13	-4.70	-6.77	-7.35	0.58	-7.06
5	-5.13	-4.92	0.21	-5.03	-7.33	-7.82	0.49	-7.58
6	-5.23	-5.10	0.13	-5.17	-7.32	-7.79	0.47	-7.56
7	-5.28	-5.11	0.17	-5.20	-7.58	-7.98	0.40	-7.78
8	-4.99	-4.67	0.32	-4.83	-7.14	-7.79	0.65	-7.47
9	-5.40	-4.96	0.44	-5.18	-7.51	-7.90	0.39	-7.71
10	-5.40	-5.14	0.26	-5.27	-7.51	-8.15	0.64	-7.83
11	-4.92	-4.75	0.17	-4.84	-7.11	-7.39	0.28	-7.25
12	-5.16	-5.01	0.15	-5.09	-7.51	-7.94	0.43	-7.73
13	-5.01	-4.62	0.39	-4.82	-7.06	-7.38	0.32	-7.22
14	-5.60	-5.33	0.27	-5.47	-8.06	-8.62	0.56	-8.34
15	-5.44	-5.27	0.17	-5.36	-7.85	-8.35	0.50	-8.10
16	-5.28	-5.06	0.22	-5.17	-7.57	-7.96	0.39	-7.77
Averaged	-5.21	-4.97	0.24	-5.09	-7.41	-7.90	0.49	-7.66
Mean	-5.09		0.24		-7.66		0.49	

Physical cable length as obtained by OTDR	20.01	km
Number of splices from A to B	9.00	pcs

Acceptance criteria

- all averaged values per fibre (column G and K) below required total allowable loss
- differences of measurements in both directions may not differ more than 0.5 dB at 1550 nm and not more than 0.7 dB at 1310 nm for each fiber

Requirements:

	1550 nm	1310 nm
Cable Attenuation per km (dB):	0.23	0.35
Total Physical Cable Length (km):	20.01	20.01
Splice Loss Mean Value (dB):	0.05	0.05
Total Number of Splices:	9	9
Maximum Connector Loss (dB):	0.50	0.50
Total Number of Connectors:	2	2
Allowance for short section (dB):	0.00	0.00
Total Allowable Loss (dB):	6.05	8.45

Approved by Contractor Representative:	Witnessed and signed PMC Representative	Accepted and signed MoICT Representative
Signature: _____	Signature: _____	Signature: _____
Name: _____	Name: _____	Name: _____
Date: _____	Date: _____	Date: _____

ANNEX I: SHOP DRAWING / AS-BUILT SPECIFICATIONS FOR GIS DATA SUBMITTED TO MINISTRY OF DIGITAL ECONOMY AND ENTREPRENEURSHIP (MODEE)

GIS data for Broadband is a consistence of integrated GIS layers represents GIS database structure of Broadband Sector, and these data classified to:

- 1- **Operational GIS Layers** (Duct cables, Arial Cable, Duct rout, Connection point, Aggregate, Manhole, Hand hole, poles, pull box, splice)
- 2- **Assistant GIS Layers** (Administrative Boundaries, Landmarks, Streets, Base Maps...)

A set of general requirements and technical rules apply to any submitted GIS data in order to match our needs in this field.

1- General Requirements:

- a) All GIS data submitted should be in **3GIS** format.
- b) Contractor should prepare all required deliveries with ESRI format; it should be according to the required model, noting that 3GIS license will be provided inside the Ministry building to be used by the contractor's survey engineer for converting all plans to their final format (3GIS).
- c) As-Built GIS data should be referenced in the same Coordinate system that is used by MODEE, which is the JTM.
- d) Shop drawing GIS data should be referenced in the same Coordinate system that is used by DLS.
- e) The extent of submitted data should be covering the concerned area or the projected area.
- f) The submitted data should be checked carefully and to be closer to our requirements before delivery.
- g) It is preferred to receive a sample copy for checking (one copy in case of more than one copy should be submitted) of As-built data until the final ok is given for submitting a final copy.
- h) All GIS data that is not produced by contractors and will be taken from governmental institutions should be obtained legally (e.g. Base Maps, Streets, Organizational Maps ...).
- i) all submitted should be in digital copy and delivered on a DVD.
- j) Hard copy should delivered.

2- Technical Rules:

GIS layers contained from two components (Spatial and Attribute information), so when we use a GIS as a tool to reflect Broad Band network information, we need to apply a set of rules and standards to govern this process.

a) **Spatial Information:**

The spatial information very important, so there are several rules and restrictions govern the behaviors and relationships between features in the same layer or features of different layers. The data should be topologically clean and free from topological errors (e.g., unsnapped dangling nodes, extra nodes, or unnecessary intersections).

The main rules and restrictions that should be taken in consideration when we are dealing with GIS broadband data are:

1- Connectivity: Lines in networks should be snapped to each other and no dangles should be appeared at connection points of lines. Also, nodes (accessories or manhole) should be snapped to lines.

2- Behavior of Features: Nodes split lines where it is located on and make it two different features.

3- Adjacency: Features mustn't overlap or having gaps (slivers) when we are dealing with polygons layers.

4- Coincidence: Broadband lines should be appeared within streets boundaries and in the Wright side (right or left) of street with no crossing of parcels or plots.

b) **Attribute Information:**

Attribute information reflects the description of features (Duct lines, manholes and fittings), so it is very important to be filled correctly as follow:

1- All records of attribute table should be filled completely; any empty values will be meaningless.

2- Fields format should be the same as in MODEE.

Base Maps (Polygons):

DLS maps attribute information should contain DLS Key

Organizational Maps

Landmarks layers:

attribute information should contain the following fields: (Landmark Type and Landmark Name (English and Arabic)).

Streets (Polygons):

attribute information of streets layer should contain the following fields: (Street Name (English and Arabic), street acquisitions).

3- GIS layers:

Data for NBN network should contain the following layers:

Layer Name	Layer Type	Layer Description
Duct Route Civil	Line	This Layer contains all routes that underground
Arial Cable Fiber	Line	The cable which is over head on poles
Duct cable Fiber	Line	The cable which is underground
Aggregate	Point	This layer represents the place where cables distribute from
Aggregate Boundary	Polygon	This layer represents the boundary of each aggregate
Manhole	Point	Cables get through and using for Duct cables
Hand Hole	Point	Cables get through and using for Duct cables
Connection Point	Point	School, government and Health entities
Poles	Point	Where overhead cables connect to gather
Pull Box	Points	The end place of the cable when entering the connection point
Splice	Point	Where two or more cables connect together
Streets	Polygons	Base map
DLS	Polygons	Parcels of the land (base map) The attribute information should contain DLS Key
R.O. W	Line	The acquisition of the street
Landmarks	Point	

Attribute Data

Layer Name	Field	Type
Duct Route Civil	Number_of_duct Available_duct Status Trench_Type Pipe_Type Measured_Length Route_ID	Integer Integer Text Text Text Double Text
Arial Cable Fiber	Cable_id Cable_type Cable_size Dedicated_fiber Measured_Length Module No.-Agg No Cable Kind	String Text Integer String Double Text Text
Duct Cable Fiber	Cable id Cable_type Cable_size Dedicated_fiber Measured_length Module No.-Agg No Cable_Kind	String Text Integer String Double Text Text
Aggregate	Aggregate_id Name (Arabic) ODF1_Cable Coordinate	String Text String Double
Aggregate Boundary	Module No.-Agg No AGG_Name	Text Text
Manhole	Structure_number status Structure_ID Type Coil Coordinate Coil_Type	String Text String Text Double Double Text
Hand Hole	Structure_number status Structure_ID Type Coil Coordinate Coil_Type	String Text String Text Double Double Text

Connection point	Connection_point-id Arabic_Name English_name Coordinate Fiber_Allocation_Tx Fiber_Allocation_Rx Distance_from_AGG Type AGG_NO National_ID Input ports Output ports	String Text Text Double String String Double Text Text Double Integer Integer
Poles	Pole_id Pole_number Coordinate Any other data requested form electricity company (column height, wire type, sag, clearance ,steal or concrete, pole condition ...est)	String String Double
Pull Box	Structure_number status Structure_ID Type Coil Coordinate Coil_Type	String Text String Text Double Double Text
Splice	Splice_id Splice_number Splice_size Spare_strand Splice_type Splice_kind Coordinate Spare_strand_distance	String String Integer String Text Text Double Double
DLS	DLS key	String
Street	Arabic_Name English_name	Text Text
R.O.W	Owner	Text
Landmarks	Arabic_Name	Text

ANNEX J: SERVICE LEVEL AGREEMENT (SLA)

The contractor's prices in his BOQ shall include all costs incurred by him to provide the following terms for the Service Level Agreement (SLA) in addition to the cost of other requirements defined in tender documents:

A. Procedural:

1. The Contractor has to assign a Manager/Supervisor acting as a contact person and problem solver, including emergency phone number(s) open 24 hours, Email, and specified office location and proper warehousing facilities.
2. The Engineer is to specify a contact person authorized to report and follow-up all maintenance activities until full clearance of the reported issue, including emergency phone number open 24 hours, Email.
3. Steps required to initiate work process:
 - MODEE informs the Contractor of the problem, by MODEE's Personnel.
 - Visit to the site(s) is coordinated by the Contractor with MODEE within 2 hours to determine the fault, supported with the necessary skills and equipments.
 - Accordingly the MODEE shall inform the concerned authorities/schools directors, entities, etc. of the possible visit(s) to their sites by the contractor.
 - Upon works completion, the Contractor should call for test acceptance and finalize the required documentation, including the As-built modifications resulting from such works, for future incorporation to the As-built by MODEE.
 - Completion of the works means that the Contractor should finish all the needed works (Civil & Fiber) for repairing a Fiber Cut or Route Transfer, and have everything in working order during completion times stated in the SLA of Annex J of the RFP and if it was found later during the hand over stage that the Contractor did not execute the works properly in accordance with the Contract Requirements, and was not properly done, then MODEE is entitled to apply the penalties and other measures shown below in table #4.

B. Intervention Time

1. The Contractor's response time shall be 2 hours after MODEE inform him of the fiber fault or cable transfer.
2. The Contractor's maintenance team shall be available 24/7.
3. The Contractor shall inform the MODEE's representative to attend the tests and shall provide him with documented reports that shall reflect the As-Built.
4. The contractor shall comply with the response and resolution times as shown in tables below, noting that if the contractor doesn't comply with these times; then he shall pay to MODEE the penalties shown in table-4:.

a. Duct Cable:

	Description	Response Time (Available on Site)	Resolution Time (Time To Complete works including all permits)
1	Repairing and replacing the existing damaged ducts and cable for distance up to 350m with all related civil and Fiber works (defined in the tender documents)	Two Hours	One Day
2	Repairing and replacing the existing damaged ducts and cable for distance more than 350m with all related civil and Fiber works	Two Hours	One day for every 350 m above first 350m
3	F.O cable Installation and Splicing up to 500m (with all needed works defined in the tender documents).	Two Hours	Five Hours
4	F.O cable Installation and Splicing up to 1000m (with all needed works defined in the tender documents).	Two Hours	Seven Hours
5	F.O cable Installation and Splicing for more 1000m (with all needed works defined in the tender documents).	Two Hours	Nine Hours

Table-1

- في حال طلب المهندس المشرف من المقاول إصلاح القطع بشكل مؤقت فيجب على المقاول القيام بذلك وحسب بنود جدول الكميات و بناءً على تعليمات المهندس المشرف.

b. ADSS Cable:

	Description	Response Time (Available on Site)	Resolution Time (Time To Complete works including all permits)
1	F.O cable Installation and Splicing up to 300m (with all needed works defined in the tender documents).	Two Hours	Five Hours
2	F.O cable Installation and Splicing up to 1000m (with all needed works defined in the tender documents).	Two Hours	One Day
3	F.O cable Installation and Splicing for more 1000m (with all needed works defined in the tender documents).	Two Hours	Five Hours for every 300m above first 1000m

Table-2

- في حال طلب المهندس المشرف من المقاول إصلاح القطع بشكل مؤقت فيجب على المقاول القيام بذلك وحسب بنود جدول الكميات و بناءً على تعليمات المهندس المشرف.

c. ADSS routes Transferring:

	Description	Response Time (Available on Site)	Resolution Time (Time To Complete works including all permits)
1	F.O cable Installation and Splicing.	Two Hours	Three Hours for every 200 m

Table-3

d. Penalties:

MODEE is entitled to apply penalties on the contractor in accordance with the level of importance for the work and for a certain duration as shown in table-4, if the bidder doesn't fulfill the cut repair within the time frame shown in this table; then MODEE shall perform all cut repairs as it sees fit or through a third party to fix the problem, and according to the following criteria; noting that all cost incurred by MODEE to fix the problem shall be at the expense of the contractor:

Priority	Work Definition	Penalties
1	<ul style="list-style-type: none"> ▪ Fiber cut on government entity. ▪ Fiber cut on a main route. ▪ more than 5 schools are affected. 	A penalty of (75) JD will be applied for each (Five Hours) pass the resolution time, and will continue for one day, then a penalty of (150) JD shall be applied for each (Five Hours) for another one day, after that, a third party will be called to fix the problem on the expenses of the contractor
2	<ul style="list-style-type: none"> ▪ ADSS Cable transferring (According to IDECO request) 	(50) JD will be applied for each (Three Hours) pass the resolution time, and will continue for one day, then a penalty of (100) JD shall be applied for each (Three Hours) for another one day, a third party will be called to fix the problem on the expenses of the contractor
3	<ul style="list-style-type: none"> ▪ Fiber cut on a route (less than 5 schools are affected). 	A penalty of (50) JD will be applied for each (Five Hours) pass the resolution time, and will continue for one day, then a penalty of (100) JD shall be applied for each (Five Hours) for another one day, after that, a third party will be called to fix the problem on the expenses of the contractor

Table-4

ANNEX K: LIST OF EXISTING NORTH REGION (IRBID, NORTH GHOUR, JARASH, AJLOUN, AND MAFRAQ) SITE NAMES

AGG #	Type	Region	اسم الموقع	الرقم
M2-AGG14	مدارس / AGG	الرمثا	الشجره الثانوية للبنات الاولى	1
M2-AGG14	مدارس	الرمثا	الشجره الثانوية للبنين	2
M2-AGG14	مدارس	الرمثا	عائشة بنت ابي بكر الاساسية المختلطة	3
M2-AGG14	مدارس	الرمثا	الذنيبه الثانوية للبنات	4
M2-AGG14	مدارس	الرمثا	الذنيبه الثانوية للبنين	5
M2-AGG14	مدارس	الرمثا	الطره الثانوية للبنات	6
M2-AGG14	مدارس	الرمثا	الطره الثانوية للبنين	7
M2-AGG14	مدارس	الرمثا	اليرموك الاساسية للبنات	8
M2-AGG14	مدارس	الرمثا	أمنة بنت وهب الاساسية للبنات	9
M2-AGG14	مدارس	الرمثا	جعفر الطيار الاساسية للبنين	10
M2-AGG14	مدارس	الرمثا	حليمه السعدية الأساسية المختلطة	11
M2-AGG14	مدارس	الرمثا	خديجة بنت خويلد الاساسية المختلطة	12
M2-AGG14	مدارس	الرمثا	شرحبيل بن حسنة الاساسية للبنين	13
M2-AGG14	مدارس	الرمثا	عمراره الثانوية للبنين	14
M2-AGG14	مدارس	الرمثا	عمراره الثانويه للبنات	15
M2-AGG14	مؤسسات صحية	الرمثا	م.صحي سهل حوران الشامل	16
M2-AGG15	مدارس / AGG	اربد	النعيمه الثانوية الشاملة للبنات	17
M2-AGG15	مدارس	اربد	النعيمه الاساسية المختلطة	18
M2-AGG15	مدارس	اربد	النعيمه الاساسية للبنات	19
M2-AGG15	مدارس	اربد	النعيمه الاساسية للبنين	20
M2-AGG15	مدارس	اربد	ابن تيمية الاساسية للبنين	21
M2-AGG15	مدارس	اربد	ابن زيدون الاساسية للبنين	22
M2-AGG15	مدارس	اربد	حمد الفرحان الثانوية للبنين	23

M2-AGG15	مدارس	اربد	شطنا الاساسية المختلطة	24
M2-AGG15	مدارس	اربد	كتم /ث ش للبنين	25
M2-AGG15	مدارس	اربد	كتم الاساسية للبنات	26
M2-AGG15	مدارس	اربد	كتم الاساسية للبنين	27
M2-AGG15	مؤسسات صحية	اربد	م.صحي النعيمة	28
M2-AGG16	مدارس / AGG	اربد	الحصن الثانوية الشاملة للبنات	29
M2-AGG16	مدارس	اربد	الحصن الاساسية المختلطة	30
M2-AGG16	مدارس	اربد	الحصن الاساسية للبنين	31
M2-AGG16	مدارس	اربد	الحصن المهنية الثانوية للبنات	32
M2-AGG16	مدارس	اربد	الحصن/س/مخ/الجديدة	33
M2-AGG16	مدارس	اربد	ابو حنيفة الاساسية للبنين	34
M2-AGG16	مدارس	اربد	ابو ذر الغفاري الاساسية للبنين	35
M2-AGG16	مدارس	اربد	ابوالقاسم الشابي الاساسية للبنين	36
M2-AGG16	مدارس	اربد	اسماء الثانوية الشاملة للبنات	37
M2-AGG16	مدارس	اربد	البترء الوردية الاساسية المختلطة	38
M2-AGG16	مدارس	اربد	الخنساء الاساسية للبنات	39
M2-AGG16	مدارس	اربد	الصريح الاساسية للبنين	40
M2-AGG16	مدارس	اربد	الصريح الثانوية المختلطة	41
M2-AGG16	مدارس	اربد	الصريح/س/بنين/الجديدة	42
M2-AGG16	مدارس	اربد	المعتصم الاساسية للبنين	43
M2-AGG16	مدارس	اربد	الملك عبدالله /ث ش للبنين	44
M2-AGG16	مدارس	اربد	الملكة رانيا /ث ش المختلطة	45
M2-AGG16	مدارس	اربد	خديجة بنت خويلد الاساسية للبنات	46
M2-AGG16	مدارس	اربد	خليل السالم الشاملة الثانوية للبنين	47
M2-AGG16	مدارس	اربد	عمرالافي الثانوية الشاملة للبنين	48
M2-AGG16	مدارس	اربد	كتم الثانوية الشاملة للبنات	49
M2-AGG16	مؤسسات صحية	اربد	م.صحي الصريح	50

M2-AGG16	مؤسسات حكومية	اربد	مكتب أشغال بني عبيد	51
M2-AGG16	مدارس	اربد	ميسلون الاساسية المختلطة	52
M2-AGG17	مدارس / AGG	اربد	دير يوسف الثانوية الشاملة المختلطة	53
M2-AGG17	مدارس	اربد	دير يوسف الاساسية للبنات	54
M2-AGG17	مدارس	اربد	دير يوسف الاساسية للبنين	55
M2-AGG17	مدارس	اربد	دير يوسف الثانوية الشاملة للبنين	56
M2-AGG17	مدارس	اربد	اروى بنت الحارث الاساسية للبنات	57
M2-AGG17	مدارس	اربد	المزار الاساسية للبنات	58
M2-AGG17	مدارس	اربد	المزار الاساسية للبنين	59
M2-AGG17	مدارس	اربد	المزار الثانوية الشاملة المختلطة	60
M2-AGG17	مدارس	اربد	المزار الثانوية الشاملة للبنين	61
M2-AGG17	مدارس	اربد	المزار/س المختلطة للبنات	62
M2-AGG17	مدارس	اربد	ايليا ابو ماضي الاساسية للبنين	63
M2-AGG17	مدارس	اربد	جحفية الثانوية الشاملة للبنات	64
M2-AGG17	مدارس	اربد	جحفية الثانوية للبنين	65
M2-AGG17	مدارس	اربد	حبكا الاساسية للبنين	66
M2-AGG17	مدارس	اربد	حبكا الثانوية الشاملة المختلطة	67
M2-AGG17	مدارس	اربد	حوفا المزار الثانوية الشاملة للبنين	68
M2-AGG17	مدارس	اربد	حوفا المزار/ث ش للبنات	69
M2-AGG17	مدارس	اربد	عنية /ث ش للبنين	70
M2-AGG17	مدارس	اربد	عنية الثانوية الشاملة للبنات	71
M2-AGG17	مدارس	اربد	عنية الاساسية المختلطة	72
M2-AGG17	مؤسسات صحية	اربد	م.صحي الفاروق	73
M2-AGG17	مؤسسات حكومية	اربد	مكتب أشغال المزار الشمالي	74
M2-AGG18	مدارس / AGG	اربد	سموع الثانوية الشاملة للبنات	75
M2-AGG18	مدارس	اربد	سموع الثانوية الشاملة للبنين	76
M2-AGG18	مدارس	اربد	سموع الاساسية للبنات	77

M2-AGG18	مدارس	اربد	سموع الاساسية للبنين	78
M2-AGG18	مدارس	اربد	جنين الصفا الثانوية الشاملة المختلطة	79
M2-AGG18	مدارس	اربد	جنين الصفا الثانوية الشاملة للبنين	80
M2-AGG18	مدارس	اربد	زمال الثانوية الشاملة للبنات	81
M2-AGG18	مدارس	اربد	زمال الثانوية الشاملة للبنين	82
M2-AGG18	مدارس	اربد	كفر كيفيا الاساسية المختلطة	83
M2-AGG18	مدارس	اربد	كفر كيفيا الاساسية للبنين	84
M2-AGG19	مدارس / AGG	اربد	السمط الاساسية المختلطة	85
M2-AGG20	مدارس / AGG	اربد	الاشرفية الثانوية الشاملة للبنات	86
M2-AGG20	مدارس	اربد	ابو القين الاساسية المختلطة	87
M2-AGG20	مدارس	اربد	كفر ركب الاساسية للبنين	88
M2-AGG20	مدارس	اربد	كفر ركب الثانوية الشاملة للبنات	89
M2-AGG20	مدارس	اربد	كفر ركب الثانوية الشاملة للبنين	90
M2-AGG21	مدارس / AGG	اربد	كفر عوان الثانوية الشاملة للبنات	91
M2-AGG21	مدارس	اربد	كفر عوان الثانوية الشاملة للبنين	92
M2-AGG21	مدارس	اربد	كفر عوان الاساسية للبنين	93
M2-AGG21	مدارس	اربد	اسماء بنت ابي بكر الاساسية المختلطة	94
M2-AGG21	مدارس	اربد	بيت ايدس الاساسية المختلطة	95
M2-AGG21	مدارس	اربد	بيت ايدس الاساسية للبنين	96
M2-AGG21	مدارس	اربد	بيت ايدس الثانوية الشاملة للبنات	97
M2-AGG21	مدارس	اربد	بيت ايدس الثانوية الشاملة للبنين	98
M2-AGG21	مدارس	اربد	جديتا الاساسية المختلطة	99
M2-AGG21	مدارس	اربد	جديتا الاساسية للبنات	100
M2-AGG21	مدارس	اربد	جديتا الثانوية الشاملة للبنات	101
M2-AGG21	مدارس	اربد	جديتا الثانوية الشاملة للبنين	102
M2-AGG21	مدارس	اربد	شرحيل ابن حسنة الاساسية للبنين	103

M2-AGG21	مدارس	اربد	طنجة الاساسية للبنين	104
M2-AGG21	مدارس	اربد	عبدالله بن رواحة الاساسية للبنين	105
M2-AGG21	مدارس	اربد	كفرابيل الاساسية للبنات	106
M2-AGG21	مدارس	اربد	كفرابيل الاساسية للبنين	107
M2-AGG21	مدارس	اربد	كفرابيل الثانوية الشاملة للبنات	108
M2-AGG21	مدارس	اربد	كفرابيل الثانوية الشاملة للبنين	109
M2-AGG21	مؤسسات صحية	اربد	م.صحي كفر عوان	110
M2-AGG21	مدارس	اربد	مصعب بن عمير الاساسية للبنين	111
M2-AGG22	مدارس / AGG	اربد	رحابا الثانوية الشاملة للبنات	112
M2-AGG22	مدارس	اربد	رحابا الثانوية الشاملة للبنين	113
M2-AGG22	مدارس	اربد	رحابا الاساسية للبنات	114
M2-AGG22	مدارس	اربد	رحابا الاساسية للبنين	115
M2-AGG22	مدارس	اربد	الزعترة الاساسية للبنين	116
M2-AGG22	مدارس	اربد	الزعترة الثانوية المختلطة	117
M2-AGG22	مدارس	اربد	زوبيا الثانوية الشاملة المختلطة	118
M2-AGG22	مدارس	اربد	زوبيا الثانوية الشاملة للبنين	119
M2-AGG22	مدارس	اربد	صمد الاساسية للبنات	120
M2-AGG22	مدارس	اربد	صمد الاساسية للبنين	121
M2-AGG23	مدارس / AGG	الاغوار الشمالية	المنشية الثانوية للبنات	122
M2-AGG23	مدارس	الاغوار الشمالية	المنشيه الثانويه للبنين	123
M2-AGG23	مدارس	الاغوار الشمالية	المنشيه الاساسية للبنين	124
M2-AGG23	مدارس	الاغوار الشمالية	الساخنه الاساسية المختلطة	125
M2-AGG23	مؤسسات حكومية	الاغوار الشمالية	الثونه الشمالية	126
M2-AGG23	مدارس	الاغوار الشمالية	الثونه الشماليه الاساسيه للبنات	127
M2-AGG23	مدارس	الاغوار الشمالية	الثونه الشماليه الاساسيه للبنين	128

M2-AGG23	مدارس	الاعوار الشمالية	الشونه الشماليه الثانويه للبنات	129
M2-AGG23	مدارس	الاعوار الشمالية	الشونه الشماليه الثانويه للبنين	130
M2-AGG23	مدارس	الاعوار الشمالية	العراشه والفضيين الاساسية المختلطة	131
M2-AGG23	مدارس	الاعوار الشمالية	الملك طلال الثانويه للبنين	132
M2-AGG23	مدارس	الاعوار الشمالية	اليرموك الاساسيه للبنين	133
M2-AGG23	مدارس	الاعوار الشمالية	قليعات الثانويه للبنات	134
M2-AGG23	مؤسسات صحية	الاعوار الشمالية	لواء الاعوار الشمالية	135
M2-AGG23	مؤسسات صحية	الاعوار الشمالية	مستشفى معاذ بن جبل	136
M2-AGG23	مؤسسات حكومية	الاعوار الشمالية	مكتب أشغال الاعوار الشمالية	137
M2-AGG23	مدارس	الاعوار الشمالية	وقاص الثانويه المختلطة	138
M2-AGG24	مدارس / AGG	الاعوار الشمالية	المشارع الثانويه للبنات الاولى	139
M2-AGG24	مدارس	الاعوار الشمالية	المشارع الثانويه للبنين	140
M2-AGG24	مدارس	الاعوار الشمالية	المشارع الاساسيه للبنين	141
M2-AGG24	مدارس	الاعوار الشمالية	المشارع الثانويه الجديدة للبنات	142
M2-AGG24	مدارس	الاعوار الشمالية	الامام الشافعي الاساسية للبنين	143
M2-AGG24	مدارس	الاعوار الشمالية	الزمالية الاساسية للبنين	144
M2-AGG24	مدارس	الاعوار الشمالية	الزمالية الثانويه للبنات	145
M2-AGG24	مؤسسات حكومية	الاعوار الشمالية	المعير الشمالي	146
M2-AGG24	مدارس	الاعوار الشمالية	أمنة بنت وهب الاساسية للبنات	147
M2-AGG24	مدارس	الاعوار الشمالية	جسر الشيخ حسين الاساسيه للبنين	148
M2-AGG24	مدارس	الاعوار الشمالية	جسر الشيخ حسين الثانويه للبنات	149
M2-AGG24	مؤسسات حكومية	الاعوار الشمالية	جمرك جسر الشيخ حسين	150

M2-AGG24	مدارس	الاعوار الشمالية	شرحبيل بن حسنة /س/للبنين	151
M2-AGG24	مدارس	الاعوار الشمالية	طبقة فحل الاساسية المختلطة	152
M2-AGG24	مدارس	الاعوار الشمالية	طبقة فحل الاساسية للبنين	153
M2-AGG24	مؤسسات صحية	الاعوار الشمالية	مستشفى أبي عبيدة	154
M2-AGG24	مؤسسات صحية	الاعوار الشمالية	مكتب ملاريا الاعوار الشمالية	155
M2-AGG24	مدارس	الاعوار الشمالية	وادي الريان الثانوية للبنات	156
M2-AGG24	مدارس	الاعوار الشمالية	وادي الريان الثانوية للبنين	157
M2-AGG25	مدارس / AGG	الاعوار الشمالية	كريمه الثانويه للبنين	158
M2-AGG25	مدارس	الاعوار الشمالية	كريمه الثانويه للبنات	159
M2-AGG25	مدارس	الاعوار الشمالية	كريمة الجنوبية الاساسية للبنين	160
M2-AGG25	مدارس	الاعوار الشمالية	ابو سيدو الاساسيه للبنات	161
M2-AGG25	مدارس	الاعوار الشمالية	ابو هابيل الاساسية المختلطة	162
M2-AGG25	مدارس	الاعوار الشمالية	السليخات الاساسية المختلطة الاولى	163
M2-AGG25	مدارس	الاعوار الشمالية	السليخات الاساسية للبنين الثانية	164
M2-AGG25	مدارس	الاعوار الشمالية	القرن الاساسية المختلطة	165
M2-AGG25	مدارس	الاعوار الشمالية	حليمة السعدية الثانوية بنات	166
M2-AGG25	مدارس	الاعوار الشمالية	وادي الريان الثانوية المهنية للبنين	167

AGG #	Type	Region	اسم الموقع	الرقم
M3-AGG1	مدارس / AGG	جرش	اسد بن الفرات الثانوية الشاملة للبنين	1
M3-AGG1	مدارس	جرش	الجنيدية الأساسية للبنين	2
M3-AGG1	مدارس	جرش	الجنيدية الثانوية الشاملة المختلطة	3
M3-AGG1	مدارس	جرش	الفيحاء الأساسية للبنات	4
M3-AGG1	مدارس	جرش	الفيحاء الاساسيه المختلطة	5
M3-AGG1	مدارس	جرش	المشيرة الغربية الثانوية الشاملة للبنات	6
M3-AGG1	مدارس	جرش	المشيرة الغربية الثانوية الشاملة للبنين	7
M3-AGG1	مدارس	جرش	ام الزيتون الاساسية المختلطة	8
M3-AGG1	مدارس	جرش	ام الزيتون الاساسية للبنين	9
M3-AGG1	مدارس	جرش	بليلا الثانوية الشاملة للبنات المختلطة	10
M3-AGG1	مدارس	جرش	بليلا الثانوية للبنين	11
M3-AGG1	مدارس	جرش	ثغرة عصفور الاساسية المختلطة	12
M3-AGG1	مدارس	جرش	ثغرة عصفور الاساسيه للبنين	13
M3-AGG1	مدارس	جرش	خالد بن الوليد الثانوية - للبنين	14
M3-AGG1	مدارس	جرش	عمر بن الخطاب الأساسية للبنين	15
M3-AGG1	مدارس	جرش	قفقفا الاساسيه للبنين	16
M3-AGG1	مدارس	جرش	قفقفا الثانوية الشاملة للبنات	17
M3-AGG1	مدارس	جرش	كفر خل الاساسيه المختلطة	18
M3-AGG1	مدارس	جرش	كفرخل الاساسيه للبنين	19
M3-AGG1	مدارس	جرش	كفرخل الثانوية الشاملة المختلطة	20
M3-AGG2	مدارس / AGG	جرش	جرش الثانوية الشاملة للبنات	21
M3-AGG2	مؤسسات حكومية	جرش	بلدية جرش الكبرى	22
M3-AGG2	مدارس	جرش	الخنساء الثانوية الشاملة للبنات	23
M3-AGG2	مدارس	جرش	الرشايدة الاساسية المختلطة	24
M3-AGG2	مدارس	جرش	الرشايدة الاساسية للبنين	25

M3-AGG2	مدارس	جرش	الرياضي الاساسية المختلطة	26
M3-AGG2	مدارس	جرش	الشواهد الاساسيه المختلطه	27
M3-AGG2	مدارس	جرش	الشيخ مصلح الاساسية للبنات المختلطة	28
M3-AGG2	مدارس	جرش	المجر الاساسية المختلطة	29
M3-AGG2	مدارس	جرش	النبي هود الاساسية المختلطة	30
M3-AGG2	مدارس	جرش	النبي هود الاساسية للبنين	31
M3-AGG2	مدارس	جرش	أبو ذر الغفاري الأساسية للبنين	32
M3-AGG2	مؤسسات صحية	جرش	جرش	33
M3-AGG2	مدارس	جرش	جرش الاساسية للبنين	34
M3-AGG2	مؤسسات حكومية	جرش	جرش(الصناعة والتجارة)	35
M3-AGG2	مدارس	جرش	حسن الكايد الثانوية المهنية الشاملة للبنين	36
M3-AGG2	مدارس	جرش	راس المجر الاساسيه المختلطة	37
M3-AGG2	مدارس	جرش	زيد بن حارثه الثانوية الشاملة للبنين	38
M3-AGG2	مؤسسات حكومية	جرش	سلطة المياه/ ادارة مياه محافظة جرش	39
M3-AGG2	مؤسسات حكومية	جرش	صندوق التنمية والتشغيل(ريادة)	40
M3-AGG2	مؤسسات حكومية	جرش	صندوق المعونة الوطنية/مكتب محافظة جرش	41
M3-AGG2	مدارس	المفرق	عين النبي الاساسية المختلطة	42
M3-AGG2	مدارس	المفرق	عين النبي الاساسية للبنين	43
M3-AGG2	مدارس	جرش	فاطمه الزهراء الاساسيه المختلطه	44
M3-AGG2	مدارس	جرش	لبابة بنت الحارث الثانوية للبنات	45
M3-AGG2	مؤسسات حكومية	جرش	محافظة جرش	46
M3-AGG2	مؤسسات حكومية	جرش	محكمة بلدية جرش	47
M3-AGG2	مؤسسات حكومية	جرش	محكمة جرش الشرعية	48
M3-AGG2	مدارس	جرش	مخيم سوف الثانوية الشاملة للبنات	49
M3-AGG2	مدارس	جرش	مخيم سوف الثانوية الشاملة للبنين	50
M3-AGG2	مؤسسات حكومية	جرش	مديرية التربية والتعليم لمحافظة جرش	51
M3-AGG2	مؤسسات حكومية	جرش	مديرية محافظة جرش	52
M3-AGG2	مؤسسات صحية	جرش	مركز صحي جرش الشامل	53
M3-AGG2	مؤسسات صحية	جرش	مستشفى جرش	54

M3-AGG2	مدارس	جرش	مقبلة الاساسية للبنين	55
M3-AGG2	مدارس	جرش	مقبلة الثانوية الشاملة المختلطة	56
M3-AGG2	مؤسسات حكومية	جرش	مكتب احوال وجوازات محافظة جرش	57
M3-AGG2	مؤسسات حكومية	جرش	مؤسسة الاقراض الزراعي فرع جرش	58
M3-AGG2	مؤسسات حكومية	جرش	مؤسسة التدريب المهني / مركز التدريب المهني جرش	59
M3-AGG2	مؤسسات حكومية	جرش	مؤسسة التنمية الاجتماعية لمحافظة جرش	60
M3-AGG2	مؤسسات حكومية	جرش	مؤسسة تنمية اموال الايتام	61
M3-AGG2	مدارس	جرش	وادي الدير الشرقي الثانوية الشاملة للبنات	62
M3-AGG3	مدارس / AGG	جرش	سوف الثانوية الشاملة للبنات المختلطة	63
M3-AGG3	مدارس	جرش	سوف الثانوية الشاملة للبنين	64
M3-AGG3	مدارس	جرش	سوف الاساسيه للبنات	65
M3-AGG3	مدارس	جرش	سوف الاساسيه للبنين	66
M3-AGG3	مؤسسات حكومية	جرش	المؤسسة العامة للضمان الاجتماعي	67
M3-AGG3	مدارس	جرش	البرج الثانوية الشاملة المختلطة	68
M3-AGG3	مدارس	جرش	البرج الثانوية للبنين	69
M3-AGG3	مدارس	جرش	الجبارات الاساسية للبنات المختلطة	70
M3-AGG3	مدارس	جرش	الجبارات الثانوية الشاملة للبنين	71
M3-AGG3	مدارس	جرش	انس بن مالك الاساسية المختلطة	72
M3-AGG3	مدارس	جرش	باب عمان الاساسية المختلطة	73
M3-AGG3	مدارس	جرش	جرش الثانوية الشاملة للبنين	74
M3-AGG3	مدارس	جرش	دير الليات الاساسية المختلطة	75
M3-AGG3	مدارس	جرش	دير الليات الثانوية الشاملة للبنات	76
M3-AGG3	مدارس	جرش	دير الليات الثانوية الشاملة للبنين	77
M3-AGG3	مدارس	جرش	ظهر السرو الاساسية للبنين	78
M3-AGG3	مدارس	جرش	ظهر السرو الثانوية الشاملة للبنات	79
M3-AGG3	مؤسسات حكومية	جرش	مخبرات جرش	80
M3-AGG3	مدارس	جرش	نفيسه بنت الحسن الاساسية المختلطة	81
M3-AGG3	مدارس	جرش	وادي الدير الغربي الاساسيه المختلطه	82

M3-AGG4	مدارس / AGG	جرش	ساكب الثانوية الشاملة للبنات	83
M3-AGG4	مدارس	جرش	ساكب الثانوية الشاملة للبنين	84
M3-AGG4	مدارس	جرش	ساكب الاساسيه للبنين	85
M3-AGG4	مدارس	جرش	الحدادة الثانوية للبنين	86
M3-AGG4	مدارس	جرش	الحداده الثانوية الشاملة للبنات	87
M3-AGG4	مدارس	جرش	الحسينيات الاساسيه للبنين	88
M3-AGG4	مدارس	جرش	القابسي الثانويه الشامله للبنين	89
M3-AGG4	مدارس	جرش	الكته الاساسيه المختلطه	90
M3-AGG4	مدارس	جرش	الكته الاساسيه للبنين	91
M3-AGG4	مدارس	جرش	الكته الثانوية الشاملة للبنات	92
M3-AGG4	مدارس	جرش	المعراض الأساسية للبنين	93
M3-AGG4	مدارس	جرش	امنه بنت وهب الاساسية للبنات	94
M3-AGG4	مدارس	جرش	بدر الأساسية للبنين	95
M3-AGG4	مدارس	جرش	جرار النعمان القدوه الثانوية الشامله للبنين	96
M3-AGG4	مدارس	جرش	خديجه بنت خويلد الاساسية المختلطه	97
M3-AGG4	مدارس	جرش	ريمون الاساسية للبنات	98
M3-AGG4	مدارس	جرش	ريمون الاساسيه للبنين	99
M3-AGG4	مدارس	جرش	ريمون الثانوية الشاملة للبنات	100
M3-AGG4	مؤسسات صحية	جرش	م.صحي الرازي/ جرش	101
M3-AGG4	مدارس	جرش	مخيم جرش الثانوية الشاملة للبنات المختلطة	102
M3-AGG4	مؤسسات حكومية	جرش	مديرية اشغال محافظة جرش	103
M3-AGG4	مدارس	جرش	نجده الاساسيه المختلطة	104
M3-AGG4	مدارس	جرش	نحله الاساسيه للبنين	105
M3-AGG4	مدارس	جرش	نحله الثانوية الشاملة للبنات	106
M3-AGG4	مؤسسات حكومية	جرش	وزارة العدل / محكمة بداية جرش	107
M3-AGG4	مدارس	عجلون	الصفصافة الأساسية المختلطة	108
M3-AGG5	مدارس / AGG	جرش	برما الثانوية الشاملة للبنين	109
M3-AGG5	مدارس	جرش	برما الثانوية الشاملة للبنات	110

M3-AGG5	مدارس	جرش	برما الاساسية للبنات	111
M3-AGG5	مدارس	جرش	الجزازة الثانوية للبنين	112
M3-AGG5	مدارس	جرش	الجزازة الثانوية للبنات	113
M3-AGG5	مدارس	جرش	الفواره الاساسية للبنات المختلطة	114
M3-AGG5	مدارس	جرش	المجدل الاساسية المختلطة	115
M3-AGG5	مدارس	جرش	عليمون الاساسية للبنين	116
M3-AGG5	مدارس	جرش	عليمون الثانوية المختلطة	117
M3-AGG6	مدارس / AGG	جرش	جبه الثانويه الشاملة المختلطة	118
M3-AGG6	مدارس	جرش	جبة الثانوية الشاملة للبنين	119
M3-AGG6	مدارس	جرش	جبة الاساسية للبنين	120
M3-AGG6	مدارس	جرش	الراية الاساسية المختلطة	121
M3-AGG6	مدارس	جرش	الرايه الاساسية للبنين	122
M3-AGG6	مدارس	جرش	الرحمانية الاساسية المختلطة	123
M3-AGG6	مدارس	جرش	المصطبة الثانوية الشاملة للبنات	124
M3-AGG6	مدارس	جرش	تلعة الرز الثانوية المختلطة	125
M3-AGG6	مدارس	جرش	تلعه الرز الثانوية للبنين	126
M3-AGG6	مدارس	جرش	مرصع الاساسية للبنين	127
M3-AGG6	مدارس	جرش	مرصع الثانوية الشاملة للبنين	128
M3-AGG6	مدارس	جرش	مرصع الثانوية للبنات	129

AGG #	Type	Region	اسم الموقع	الرقم
M4-AGG1	مدارس / AGG	عجلون	الساخنة الثانوية الشاملة للبنات	1
M4-AGG1	مدارس	عجلون	الساخنة الثانوية الشاملة للبنين	2
M4-AGG1	مدارس	عجلون	السفينة الثانوية الشاملة للبنات	3
M4-AGG1	مدارس	عجلون	السفينة الثانوية للبنين	4
M4-AGG1	مدارس	عجلون	بلاص الاساسية المختلطة	5
M4-AGG1	مدارس	عجلون	بلاص الثانوية الشاملة للبنات	6
M4-AGG1	مدارس	عجلون	بلاص الثانوية الشاملة للبنين	7
M4-AGG1	مدارس	عجلون	دحوس الاساسية المختلطة	8
M4-AGG1	مدارس	عجلون	راجب الثانوية الشاملة للبنات	9
M4-AGG1	مدارس	عجلون	راجب الثانوية الشاملة للبنين	10
M4-AGG2	مدارس / AGG	عجلون	عنجرة الاساسية المختلطة	11
M4-AGG2	مؤسسات حكومية	عجلون	بلدية عجلون / منطقة عنجرة	12
M4-AGG2	مؤسسات حكومية	عجلون	بنك تنمية المدن والقرى	13
M4-AGG2	مدارس	عجلون	الخنساء الاساسية المختلطة	14
M4-AGG2	مؤسسات حكومية	عجلون	محافظة عجلون / متصرفية لواء قصبه عجلون	15
M4-AGG2	مدارس	عجلون	عائشة الباعونية الاساسية للبنات	16
M4-AGG2	مدارس	عجلون	عنجرة الاساسية للبنين	17
M4-AGG2	مدارس	عجلون	عنجرة الثانوية الشاملة للبنات	18
M4-AGG2	مدارس	عجلون	عنجرة الثانوية الشاملة للبنين	19
M4-AGG2	مؤسسات صحية	عجلون	م.صحي عجلون	20
M4-AGG2	مؤسسات حكومية	عجلون	مديرية التربية والتعليم لمحافظة عجلون	21
M4-AGG2	مؤسسات حكومية	عجلون	مديرية زراعة محافظة عجلون	22
M4-AGG2	مؤسسات حكومية	عجلون	وزارة البيئة / مديرية البيئة لمحافظة عجلون وجرش	23
M4-AGG2	مؤسسات حكومية	عجلون	وزارة المياه والري / ادارة مياه محافظة عجلون المركزي	24

M4-AGG3	مدارس / AGG	عجلون	الأميرة عائشة الثانوية الشاملة للبنات	25
M4-AGG3	مؤسسات حكومية	عجلون	المؤسسة العامة للضمان الاجتماعي / مكتب عجلون	26
M4-AGG3	مؤسسات حكومية	عجلون	بلدية عجلون الكبرى	27
M4-AGG3	مؤسسات حكومية	عجلون	بلدية عجلون الكبرى /منطقة الروابي	28
M4-AGG3	مؤسسات حكومية	عجلون	دائرة ضريبة الدخل والمبيعات لمحافظة عجلون	29
M4-AGG3	مدارس	عجلون	اشتيفينا الأساسية المختلطة	30
M4-AGG3	مدارس	عجلون	الطيارة الأساسية المختلطة	31
M4-AGG3	مدارس	عجلون	الكرامة الأساسية المختلطة	32
M4-AGG3	مؤسسات حكومية	عجلون	محكمة عجلون الشرعية	33
M4-AGG3	مؤسسات حكومية	عجلون	مخبرات عجلون	34
M4-AGG3	مؤسسات حكومية	عجلون	مديرية اثار محافظة عجلون	35
M4-AGG3	مدارس	عجلون	عجلون الاساسية المختلطة	36
M4-AGG3	مدارس	عجلون	عجلون الثانوية الشاملة للبنات	37
M4-AGG3	مدارس	عجلون	عجلون الثانوية الشاملة للبنين	38
M4-AGG3	مدارس	عجلون	عين جنا الثانوية الشاملة للبنات	39
M4-AGG3	مدارس	عجلون	عين جنا الثانوية الشاملة للبنين	40
M4-AGG3	مؤسسات حكومية	عجلون	مديرية احوال مدنيه وجوازات عجلون	41
M4-AGG3	مؤسسات صحية	عجلون	م.صحي اشتيفينا الشامل	42
M4-AGG3	مؤسسات حكومية	عجلون	مديرية التنمية الاجتماعية	43
M4-AGG3	مؤسسات حكومية	عجلون	مديرية الشؤون البلدية لمحافظة عجلون	44
M4-AGG3	مؤسسات حكومية	عجلون	مديرية الصناعة والتجارة لمحافظة عجلون	45
M4-AGG3	مؤسسات حكومية	عجلون	مديرية تسجيل اراضي عجلون	46
M4-AGG3	مؤسسات حكومية	عجلون	مديرية عمل عجلون	47
M4-AGG3	مؤسسات حكومية	عجلون	مديرية مالية عجلون	48
M4-AGG3	مؤسسات حكومية	عجلون	مراقبة ديوان المحاسبة / عجلون	49
M4-AGG3	مؤسسات حكومية	عجلون	مديرية سياحة محافظة عجلون	50

M4-AGG3	مؤسسات حكومية	عجلون	مكتب افتاء محافظة عجلون	51
M4-AGG3	مؤسسات حكومية	عجلون	مؤسسة الأقرض الزراعي	52
M4-AGG3	مؤسسات حكومية	عجلون	مؤسسة تنمية اموال الاوقاف / مكتب محافظة عجلون	53
M4-AGG3	مؤسسات حكومية	عجلون	وزارة الاشغال العامة / مديرية اشغال محافظة عجلون	54
M4-AGG3	مؤسسات حكومية	عجلون	وزارة العدل / محكمة بداية عجلون	55
M4-AGG3	مؤسسات صحية	عجلون	مركز صحي عين جنا	56
M4-AGG4	مدارس / AGG	عجلون	رأس منيف الثانوية للبنات	57
M4-AGG4	مدارس	عجلون	عبلين الأساسية المختلطة	58
M4-AGG4	مدارس	عجلون	الزبير بن العوام الأساسية المختلطة	59
M4-AGG4	مدارس	عجلون	ذات النطاقين الأساسية المختلطة	60
M4-AGG4	مدارس	عجلون	راس منيف الثانوية الشاملة للبنين	61
M4-AGG4	مدارس	عجلون	سامتا الأساسية المختلطة	62
M4-AGG4	مدارس	عجلون	صخرة الأساسية للبنات	63
M4-AGG4	مدارس	عجلون	صخرة الأساسية للبنين	64
M4-AGG4	مدارس	عجلون	صخرة الثانوية الشاملة للبنات	65
M4-AGG4	مدارس	عجلون	صخرة الثانوية الشاملة للبنين	66
M4-AGG4	مدارس	عجلون	صقر قريش الأساسية للبنين	67
M4-AGG4	مدارس	عجلون	عبين الأساسية للبنين	68
M4-AGG4	مدارس	عجلون	عبين الثانوية الشاملة للبنات	69
M4-AGG4	مدارس	عجلون	عبين الثانوية الشاملة للبنات	70
M4-AGG4	مدارس	عجلون	عبين الثانوية الشاملة للبنين	71
M4-AGG4	مؤسسات صحية	عجلون	م.صحي صخرة	72
M4-AGG5	مدارس / AGG	عجلون	راسون الثانوية الشاملة للبنات	73
M4-AGG5	مدارس	عجلون	راسون الثانوية الشاملة للبنين	74
M4-AGG5	مدارس	عجلون	الأمير حمزة بن الحسين الأساسية للبنين	75
M4-AGG5	مدارس	عجلون	الفيحاء الأساسية المختلطة	76

M4-AGG5	مدارس	عجلون	المرجم الثانوية الشاملة للبنات	77
M4-AGG5	مدارس	عجلون	المرجم الثانوية الشاملة للبنين	78
M4-AGG5	مدارس	عجلون	الملك طلال الثانوية الشاملة للبنين	79
M4-AGG5	مدارس	عجلون	صنعار الثانوية الشاملة للبنات	80
M4-AGG5	مدارس	عجلون	صنعار الثانوية الشاملة للبنين	81
M4-AGG5	مدارس	عجلون	عرجان الثانوية الشاملة للبنات	82
M4-AGG6	مدارس / AGG	عجلون	حلاوة الثانوية الشاملة للبنات	83
M4-AGG6	مدارس	عجلون	حلاوة الثانوية الشاملة للبنين	84
M4-AGG6	مدارس	عجلون	الهاشمية الأساسية للبنات	85
M4-AGG6	مدارس	عجلون	الهاشمية الأساسية للبنين	86
M4-AGG6	مدارس	عجلون	الهاشمية الثانوية الشاملة للبنات	87
M4-AGG6	مدارس	عجلون	الهاشمية الثانوية الشاملة للبنين	88
M4-AGG6	مدارس	عجلون	أوصرة الثانوية الشاملة للبنات	89
M4-AGG6	مدارس	عجلون	أوصرة الثانوية الشاملة للبنين	90
M4-AGG6	مدارس	عجلون	باعون الثانوية الشاملة للبنات	91
M4-AGG6	مدارس	عجلون	باعون الثانوية الشاملة للبنين	92
M4-AGG7	مدارس / AGG	عجلون	الملك عبد الله الثاني بن الحسين الثانوية الشاملة للبنين	93
M4-AGG7	مدارس	عجلون	العامرية الثانوية للبنات	94
M4-AGG7	مدارس	عجلون	الوهادنة الثانوية الشاملة للبنات	95
M4-AGG7	مدارس	عجلون	الوهادنة الثانوية الشاملة للبنين	96
M4-AGG7	مدارس	عجلون	خديجة بنت خويلد الأساسية المختلطة	97
M4-AGG7	مدارس	عجلون	خولة بنت الأزور الأساسية المختلطة	98
M4-AGG7	مدارس	عجلون	عز الدين أسامة الأساسية للبنين	99
M4-AGG7	مدارس	عجلون	كفرنجة الأساسية الجديدة للبنات	100
M4-AGG7	مدارس	عجلون	كفرنجة الأساسية للبنين	101
M4-AGG7	مدارس	عجلون	كفرنجة الثانوية الشاملة للبنات	102

M4-AGG7	مدارس	عجلون	كفرنجة الثانوية الشاملة للبنين	103
M4-AGG7	مؤسسات صحية	عجلون	م.صحي الامير الحسن (كفرنجة)	104
M4-AGG7	مؤسسات حكومية	عجلون	مكتب أشغال كفرنجة	105

copy not for sale

AGG #	Type	Region	اسم الموقع	الرقم
M7-AGG 05	مدارس / AGG	المفرق	بلعما الثانوية الشاملة للبنين	1
M7-AGG 05	مدارس	المفرق	بلعما / الحي الشمالي	2
M7-AGG 05	مدارس	المفرق	حميد الثانوية المختلطة	3
M7-AGG 05	مدارس	المفرق	حيان الروبيض الثانوية الشاملة للبنات	4
M7-AGG 05	مدارس	المفرق	حيان المشرف الاساسية للبنين	5
M7-AGG 05	مدارس	المفرق	دحل الاساسية المختلطة	6
M7-AGG 05	مدارس	المفرق	البستان الاساسية المختلطة	7
M7-AGG 05	مدارس	المفرق	الزنية الاساسية المختلطة	8
M7-AGG 05	مدارس	المفرق	الزنيه الاساسيه للبنين	9
M7-AGG 05	مدارس	المفرق	الزنيه الثانوية الشاملة للبنات	10
M7-AGG 05	مدارس	المفرق	الزنيه الثانوية الشاملة للبنين	11
M7-AGG 05	مدارس	المفرق	الزيتونة الاساسية المختلطة	12
M7-AGG 05	مدارس	المفرق	الزيتونة الاساسيه للبنين	13
M7-AGG 05	مدارس	المفرق	الظاهرية الاساسية المختلطة	14
M7-AGG 05	مدارس	المفرق	الكرم الاساسية المختلطة	15
M7-AGG 05	مدارس	المفرق	المراجم الاساسية المختلطة	16
M7-AGG 05	مدارس	المفرق	المراجم الاساسية للبنات	17
M7-AGG 05	مدارس	المفرق	المزرعة الاساسية المختلطة	18
M7-AGG 05	مدارس	المفرق	المزرعه الاساسيه للبنين	19
M7-AGG 05	مدارس	المفرق	النزهة الاساسية المختلطة	20
M7-AGG 05	مدارس	المفرق	النزه الاساسية للبنين	21
M7-AGG 05	مدارس	المفرق	النمرة الاساسية المختلطة	22
M7-AGG 05	مدارس	المفرق	ام صويوينه الاساسيه المختلطة	23
M7-AGG 05	مدارس	المفرق	أسماء بنت أبي بكر الأساسية للبنين المؤنثة	24
M7-AGG 05	مدارس	المفرق	بلعما الاساسية للبنات	25
M7-AGG 05	مدارس	المفرق	بلعما الاساسيه للبنين	26

M7-AGG 05	مدارس	المفرق	بلعما الثانوية الشاملة للبنات	27
M7-AGG 05	مدارس	المفرق	حميد الثانوية للبنين	28
M7-AGG 05	مدارس	المفرق	حيان الروبيض الشرقي الاساسية المختلطة	29
M7-AGG 05	مدارس	المفرق	حيان الروبيض الشرقي الثانوية الشاملة للبنين	30
M7-AGG 05	مدارس	المفرق	حيان الروبيض الغربي الاساسيه للبنين	31
M7-AGG 05	مدارس	المفرق	حيان المشرف الثانوية المختلطة	32
M7-AGG 05	مدارس	المفرق	دحل الاساسية للبنين	33
M7-AGG 05	مدارس	المفرق	رفيدة الاسلمية الاساسية للبنات	34
M7-AGG 05	مدارس	المفرق	علي بن ابي طالب الاساسية	35
M7-AGG 05	مدارس	المفرق	عمر بن الخطاب الاساسيه للبنين	36
M7-AGG 05	مدارس	المفرق	مثلث المزرعة الاساسية للبنين	37
M7-AGG 05	مدارس	جرش	ام قنطرة الاساسية للبنين	38
M7-AGG 05	مدارس	جرش	ام قنطره الاساسية للبنات	39
M7-AGG 05	مؤسسات صحية	المفرق	م.صحي بلعما	40
M7-AGG 06	مدارس / AGG	المفرق	الأمير حسين بن عبدالله الثاني الثانوية للبنين	41
M7-AGG 06	مدارس	المفرق	ام بطيمه الثانوية المختلطة	42
M7-AGG 06	مدارس	المفرق	الدقمسة الاساسية المختلطة	43
M7-AGG 06	مدارس	المفرق	الدقمسة الاساسية للبنين	44
M7-AGG 06	مدارس	المفرق	القدم الاساسية المختلطة	45
M7-AGG 06	مدارس	المفرق	المدور الاساسية المختلطة	46
M7-AGG 06	مدارس	المفرق	المدور الاساسية للبنين	47
M7-AGG 06	مدارس	المفرق	المعمرية الثانوية المختلطة	48
M7-AGG 06	مدارس	المفرق	ام بطيمة الثانوية الشاملة للبنين	49
M7-AGG 06	مدارس	المفرق	ام بطيمه الاساسيه للبنين	50
M7-AGG 06	مدارس	المفرق	حمامة العليمات الاساسية المختلطة	51
M7-AGG 06	مدارس	المفرق	حمامة العموش الاساسية للبنين	52
M7-AGG 06	مدارس	المفرق	حمامة العموش الثانوية المختلطة	53

M7-AGG 06	مدارس	المفرق	خطلة وهويشان الاساسية المختلطة	54
M7-AGG 06	مدارس	المفرق	عين بني حسن الثانوية الشاملة للبنين	55
M7-AGG 06	مدارس	المفرق	نادرة الاساسية للبنين	56
M7-AGG 06	مدارس	المفرق	نادره الثانوية المختلطة	57
M7-AGG 06	مؤسسات صحية	المفرق	م.صحي نادرة	58

copy not for sale

ANNEX L: SAFETY REQUIREMENTS OF IDECO

متطلبات شركة كهرباء محافظة اربد

بالإضافة الى ما ورد في الملحق رقم (1) والى ما هو وارد ادناه، فانه يترتب على المقاول قبل المباشرة بأعمال تعليق الكوابل على الأعمدة التابعة لشركة توزيع الكهرباء ان يكون على دراية تامة بكافة إجراءات السلامة العامة و المتطلبات الفنية المتبعة لدى الشركة و ان يستفسر عنها و يحصل بنفسه عليها و لن يكون صاحب العمل مسؤولا عن أي عطل او ضرر قد يلحق بالمقاول نتيجة لعدم تفهمه او اتباعه لهذه الشروط

Health and Safety

العمل على الخطوط الهوائية للفريق الأول

■ ملاحظات عامة :

على كل شخص يمارس عملاً له بالمعدات والشبكات الكهربائية أن لا يتجاوز حدود اختصاصه ومعرفة الفنية أو نوعية الأعمال المسموح له القيام بها بموجب شهادة ودرجة التحويل الممنوحة له ، ولا يجوز لأي شخص في أي حال من الأحوال أن يقوم بأي أعمال على المعدات وشبكات الفولطية المتوسطة قبل التأكد مما يلي :

- (أ) أنه شخص مسؤول ومخول للقيام بالعمل ، وعلى معرفة ودراية تامة بطبيعة المهمة التي سيقوم بها ، و عليه أن لا يقوم بالعمل إذا لم يكن واثقاً من قدرته على مواجهته حتى لو كانت رتبة شهادة التحويل التي يحملها تؤهله شكلياً وقانونياً لذلك العمل .
- (ب) أن هذه الشبكة والمعدات ميته .
- (ج) أن المعدات مستغلة تماماً ومفصلة كلياً كهربائياً عن أي معدات حية فعلاً أو معرضة للأحياء بدون اختيار القائم بالعمل .
- (د) أن المعدات مؤرضة تماماً وبكفاءة كهربائية وميكانيكية عالية وأن التاريز قد تم فسي النقاط التي تتصل عادة مع المعدات الحية والتي ممكن أن تكون معرضة لذلك ، واتخاذ كافة الإجراءات الممكنة لمنع إمكانية الوصول إلى الأجزاء الحية أثناء العمل سواء من قبل الأشخاص أو الأدوات والعدد المستعملة في العمل .
- (هـ) أن علامات التحذير والخطر قد ثبتت في الأماكن المناسبة .
- (و) أنه تم الحصول على إذن عمل حسب الأصول .

و عند مباشرة العمل لابد من عمل ما يلي :

- (1) أن يقوم بفتح الخط و/أو الخطوط فتحاً وثيقاً من جميع نقاط التغذية أو نقاط الالتقاء مع الأجزاء الأخرى من الشبكة .
- (2) أن يقوم باستعزال الخط استعزالاً وثيقاً Secured Isolation عند جميع نقاط التغذية أو الالتقاء مع الشبكة بما في ذلك استعزال محولات الفولطية أو أي معدات أخرى يحتتمل أن تكهرب الخط .
- (3) إذا كان العمل يتعلق بخطوط الفولطية المتوسطة عليه أن يقوم بإبلاغ مهندس المراقبة والتحكم أو مهندس محطات التحويل الفرعية مباشرة بعد عمليتي الفتح والاستعزال ، و ينتظر تلقي موافقة مهندس المراقبة والتحكم أو مهندس محطات التحويل الفرعية بالاستمرار بالعمل وتنفيذ العمليات التالية .
- (4) يقوم بإجراء الاختبارات التمهيدية من فحص وتفريغ الشبكات .

- (5) يقوم بتأريض الخط في محطة التحويل لشبكات الضغط المتوسط وإضافة تأريض احتياطي في موقع العمل من الجهتين .
- (6) يقوم بتثبيت إشارات التحذير في جميع النقاط التي يمكن أن يكهرب منها الخط .
- (7) يقوم بتفكيك Looking قواطع الدارة والمستعزلات Isolators وغالقات الميازيب Spout Shutters ومقابض التحكم Control Handles وأجهزة السلامة Safety Devices بالمفاتيح المخصصة لذلك ويقفل عليها في خزانة المفاتيح ويحتفظ بمفتاح الخزانة لديه حتى انتهاء العمل .

■ الخلوص عن الموصلات الحية متوسطة الفولطية :

Clearance From Medium - Voltage Live Conductors

- ✓ كقاعدة عامة على الشخص المخول أو الكفو والمسؤول أن يلاحظ وجود حواجز تمنع وصول أيًا من فريق العمل أو معداته إلى الموصلات الحية .
- ✓ مثل هذه الحواجز يمكن أن تكون من مادة عازلة أو مادة موصلة وفي هذه الحالة يجب أن تكون مؤرضة تأريضا جيدا ووثيقا .
- ✓ في الحالات التي يتعذر فيها وجود أو إقامة الحواجز فإن على الشخص المسؤول والمخول عن فريق العمل أن يراعى بأن أحداً من الفريق بشخصه ومعداته أو المواد أو الأدوات التي يستعملها أثناء العمل لن تتجاوز الحد الأدنى من الخلوص المنصوص عليه في جدول السماح الكهربائي المقرر من هيئة تنظيم قطاع الكهرباء .
- ✓ إذا كان العمل يتضمن وضع وصلات من أسلاك ، فعلى الشخص الكفو المسؤول أن يتأكد من أن هذه الأسلاك أثناء وضعها لن تتعدى الخلوص الأدنى المسموح به في الجدول التالي :

مسافة السماح الكهربائي بالنسبة للخطوط الهوائية غير المعزولة عند أقصى انحناء وفقاً للجدول التالي :

وصف قياسات السماح	11 ك.ف / 33 ك.ف
✓ السماحات الأفقية	
(1) السماحات الأفقية عن المنشآت	3م
(2) السماحات الأفقية للأراضي خارج التنظيم	2م
✓ السماحات العمودية	
(1) الارتفاع عن مستوى الأرض الفضاء	6م
(2) الارتفاع التقاطعات عن مستوى الطرق	7م
(3) الارتفاع عن خطوط أخرى عند التقاطع	2م
(4) الارتفاع عن قمم الشجار	2م
(5) الارتفاع عن سقف المنشآت القائمة	3م

تعليمات العمل على الشبكات الهوائية جهد منخفض وجهد متوسط فيما يتعلق بالفريق الثاني

يعلم الفريق الثاني عند إجراء تركيباته بان شبكة الفريق الأول تكون دائما حيه ولا يمكن امانتها من اجل عمل تركيبات كبلات الاليف الضوئية الخاصة بالفريق الثاني ولا يحق له المطالبة باطفائها .

ومع مراعاة ما ورد في تعليمات العمل على الشبكات الهوائية جهد منخفض وجهد متوسط فيما يتعلق بالفريق الأول يجب على الفريق الثاني أو أي من مستخدميهم أو من يكلفه بالعمل التقيد بما يلي عند العمل على منظومة شبكات الفريق الأول .

- (1) التأكد من انه اتخذ جميع التدابير اللازمة لضمان سلامه مكان العمل والعاملين .
- (2) التأكد بان جسم الأعمدة التي سيقوم بالتركيب عليها ميته قبل المباشرة بالعمل .
- (3) اتخاذ التدابير اللازمة من اجل ضمان السلامة للعاملين ولمستخدمي الطرق .
- (4) مراعاة عدم تجاوز حدود السماح المبينة بالملحق رقم (1) ومسافات السماح المقررة من هيئة تنظيم قطاع الكهرباء المبينة بالملحق رقم (3) من قبل العاملين لديه وعدم تجاوزها باي حال من الاحوال .
- (5) عند تصميم وتركيب كبلات الاليف الضوئية يجب على الفريق الثاني الاخذ بالحسبان المحافظة على الخلوص الادنى ما بين شبكة الفريق الأول وشبكة الفريق الثاني في جميع الاحوال الجوية والتشغيلية ويمكن للفريق الثاني اخذ المعلومات الضرورية لهذه الغاية من الفريق الأول .

ANNEX M: SAFETY REQUIREMENTS OF EDCO

متطلبات شركة كهرباء في محافظات الجنوب

بالإضافة الى ما هو وارد ادناه، فانه يترتب على المقاول قبل المباشرة بأعمال تعليق الكوابل على الأعمدة التابعة لشركة توزيع الكهرباء ان يكون على دراية تامة بكافة إجراءات السلامة العامة و المتطلبات الفنية المتبعة لدى الشركة و ان يستفسر عنها ويحصل بنفسه عليها و لن يكون صاحب العمل مسؤولا عن أي عطل او ضرر قد يلحق بالمقاول نتيجة لعدم تفهمه او اتباعه لهذه الشروط.

1. يضع المقاول في الوقت المناسب خطة عمل أولية واضحة يبين فيها المواقع التي يرغب بتركيب كوابل الألياف الضوئية على أعمدة شركة الكهرباء، موضحا فيها أولويات التنفيذ من حيث المناطق الجغرافية وعليه ان يعلم شركة الكهرباء عن المنطقة او المناطق التي يرغب مباشرة العمل بها قبل شهرين على الأقل من تاريخ المباشرة بالعمل ، لتتمكن شركة الكهرباء من اتخاذ أي إجراءات تلزم لتدعيم وتقوية أعمدتها قبل انتهاء المدة المشار إليها أعلاه بحيث يتمكن المقاول من انجاز الأعمال الخاصة به دون تأخير ، وفي الحالات التي تتطلب فترات زمنية أطول بناء على تقديرات شركة الكهرباء او في الحالات التي تتطلب تركيب أعمدة إضافية فانه يتم الاتفاق على هذه المدة في حينه.

2. يحق لشركة الكهرباء على ضوء الدراسة الفنية لخطة العمل الأولية التي يقدمها المقاول ان ترفض طلب المقاول لتركيب أي من الكوابل شريطة تقديمها اسباب رفض مقنعة لوزارة الاتصالات ومقاولها، وإذا اتضح انه ليس بالإمكان تلبية طلب المقاول ، فعلى كافة الأطراف دراسة البدائل المختلفة والاتفاق عليها لتمكين المقاول من انجاز الشبكة.

3. تقوم شركة الكهرباء بتقديم المشورة الفنية اللازمة لصاحب العمل ومقاوليه خلال مرحلة تركيب الكوابل ، لتتأكد شركة الكهرباء من ان أعمال التركيب تتم وفقا لمتطلباتها وحسب الشروط الفنية و إجراءات السلامة المتبعة لديها.

4. تقوم شركة الكهرباء بالإشراف على الأعمال التي يقوم بها المقاول، ويحق لشركة الكهرباء إبلاغ وزارة الاتصالات فورا عن أي اخطاء او مخالفات في اعمال التركيب التي يتم انجازها ، كما يحق لها الطلب من وزارة الاتصالات ابعاد أي من العاملين لديها او لدى أي من مقاوليها اذا تبين لها انهم يخالفون تعليمات الشركة او لا يتبعون متطلبات السلامة التي تعتمدها الشركة.

5. يحق للمقاول أو أي من موظفيه أو تابعيه الذين يتولون تركيب الكوابل المتفق على تركيبها والوصلات الخاصة بها وأعمال الصيانة المتعلقة بها الصعود على أعمدة الشبكة الكهربائية الخاصة بشركة الكهرباء ذات الضغط المنخفض او المتوسط الى مستوى يصل إلى اعلى نقطه من الكوابل الخاصة بالمقاول فقط ، ولا يجوز لأي منهم تجاوز هذا الحد الى الاعلى باي جزء من اجزاء الجسم او بأي نوع من المعدات أو الأجهزة ولأي سبب من الأسباب كما لا يجوز لهم العمل على غير الكوابل المتفق عليها ، وعلى ان يتقيد المقاول أو أي من موظفيه بتطبيق قواعد السلامة العامة المعمول بها لدى شركة الكهرباء، ويعتبر المقاول مسئولاً مسؤولياً منفردة عن اية اضرار قد تلحق بشركة الكهرباء و اموالها بالإضافة لمسؤوليته عن اية اضرار قد تلحق بموظفيه ومستخدميه و مقاوليه واي تابع له.

6. يقوم المقاول بتركيب الكوابل على اقصى ارتفاع ممكن على ان لا يقل عن خمسة امتار من اخفض نقطه من هذه الكوابل ، وذلك في حالة عدم تقاطع الكابل مع الشوارع، و في حالة التقاطع فان المسافة يجب ان لا تقل عن ستة امتار (او حسب تعليمات المهندس) شريطة ان لا تقل المسافة بين الكوابل المتفق على تركيبها والشبكات ذات الضغط المنخفض عن مسافة 1 متر ، والمسافة بين الكوابل المتفق على تركيبها والشبكات ذات الضغط المتوسط عن مسافة 3 متر ، او حسب ما يتم الاتفاق عليه مع شركة الكهرباء في حينه ، و لا يحق للمقاول اثناء عمليات الصيانة و تركيب الوصلات الاقتراب من

الشبكات الكهربائية لمسافة تقل عن المسافة المذكورة اعلاه باي جزء من اجزاء الجسم او باي نوع من المعدات أو الأجهزة ولا يحق له الوصول الى الأسلاك التابعة لشبكات شركة الكهرباء.
وفي جميع الأحوال لا تتحمل شركة الكهرباء أية مسؤولية ناجمة أو مترتبة عن أعمال المقاول وتابعيه وفقاً لما جاء في البند السابق.

7. لا يجوز للمقاول تركيب اكثر من كيبل واحد على نفس العمود.

8. بالنظر لخطورة العمل على الشبكات الحية وما يتطلبه ذلك من الصرامة والدقة في التعامل مع العاملين على هذه الشبكات فان لشركة الكهرباء او لمهندسيها صلاحية الرقابة (ان رأى ضرورة لذلك) على كواثر المقاول او كواثر مقاوليه الذين يتولون تركيب الكوابل و/او الوصلات و/او صيانة الكوابل المركبة على اعمدة شركة الكهرباء، والذين يتولون التعامل مع اجهزة شركة الكهرباء الفنية او الإدارية في الامور التي تتعلق بهذا المشروع ، ودون ان تؤثر صلاحية الرقابه تلك على مسؤوليات المقاول.

وبناء عليه يحق لشركة الكهرباء ان تطلب من وزارة الاتصالات استبعاد أي موظف من موظفي المقاول في حالة ارتكاب ذلك الموظف لاية مخالفه لتعليمات شركة الكهرباء او الإساءة الى موظفي شركة الكهرباء وعلى الوزارة ان تستجيب لهذا الطلب وعلى شركة الكهرباء تزويد الوزارة بمبررات الاستبعاد لاحقاً.
